

72
72 hydro

CATALOGO DELLE PARTI DI RICAMBIO
SPARE PARTS CATALOGUE
CATALOGUES DES PIECES DE RECHANGE
ERSATZTEILKATALOG

ed. **2003**



72

72 hydro



CATALOGO PARTI DI RICAMBIO
SPARE PARTS CATALOGUE
CATALOGUE DES PIECES
ERSATZTEILKATALOG

2003

F72

F72 hydro

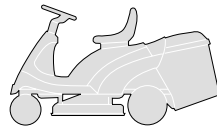

**CATALOGO PARTI DI RICAMBIO
SPARE PARTS CATALOGUE
CATALOGUE DE PIECES
ERSATZTEILKATALOG**

2003

000.0

1 / 7

COME USARE IL CATALOGO

1. Generalità

Questo catalogo contiene tutte le informazioni necessarie per ordinare correttamente i pezzi di ricambio.

2. Struttura del catalogo

In ogni pagina del catalogo sono riportate le seguenti indicazioni:

HOW TO USE THE CATALOGUE

1. General information

This catalogue contains all the information necessary for correctly ordering spare parts.

2. Structure of the catalogue

Each page of the catalogue has these indications:

COMMENT UTILISER LE CATALOGUE

1. Généralités

Ce catalogue contient toutes les indications nécessaires pour commander correctement les pièces détachées.

2. Structure du catalogue

Les indications suivantes sont reportées sur chaque page du catalogue:

WIE IST DER KATALOG ZU BENUTZEN

1. Allgemeines

Dieser Katalog enthält alle Informationen, die für die korrekte Bestellung von Ersatzteilen erforderlich sind.

2. Aufbau des Katalogs

Auf jeder Seite des Katalogs sind die folgenden Angaben wiedergegeben:

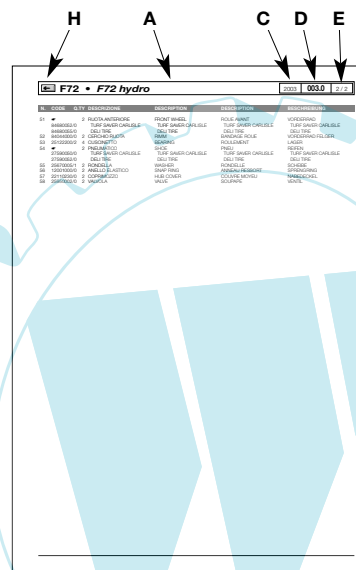
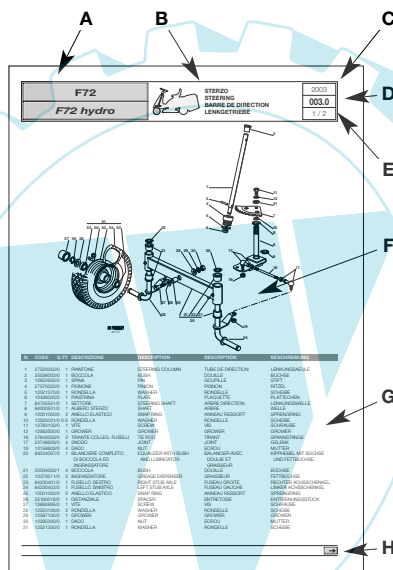

A. Macchina o serie di macchine per le quali la pagina è valida.

A. Machine or machine series to which the page applies.

A. La machine ou la série de machines auxquelles se réfère la page.

A. Maschine oder Serie der Maschine, für welche die Seite gültig ist.

B. Indicazione del gruppo con la raffigurazione in miniatura della sua collocazione sulla macchina.

B. Indication of the group with a miniature drawing showing its position on the machine.

B. L'indication du groupe avec la représentation en miniature de sa position sur la machine.

B. Bezeichnung der Gruppe mit einer Miniaturdarstellung ihrer Anbringung auf der Maschine.

C. Anno di produzione della macchina a cui si riferisce.

C. Year of production of the machine concerned.

C. L'année de fabrication de la machine concernée.

C. Herstellungsjahr der betreffenden Maschine.

D. Numerazione progressiva della tavola, secondo il seguente criterio:
- le prime tre cifre indicano il numero progressivo;
- le eventuali lettere che seguono indicano le diverse versioni alternative di quel gruppo;
- la cifra dopo il punto indica un eventuale aggiornamento nel corso della annualità indicata al punto 3.

D. Progressive numbering of the table, arranged as follows:
- the first three numbers are the progressive number;
- any letters that follow will indicate the various alternative versions of that unit;
- the number after the dot is for any updates during the year given at point 3.

D. La numérotation progressive du tableau, selon le critère suivant:
- les trois premiers chiffres indiquent le numéro progressif;
- les éventuelles lettres qui suivent indiquent les différentes versions alternatives de ce groupe;
- le chiffre après le point indique l'éventuelle mise à jour effectuée au cours de l'année indiquée au point 3.

D. Progressive Numerierung der Tafel nach folgendem Kriterium:
- die ersten drei Ziffern bezeichnen die progressive Nummer;
- die eventuellen Buchstaben, die folgen, bezeichnen die verschiedenen alternativen Versionen dieser Gruppe;
- die Ziffer nach dem Punkt bezeichnet einen eventuellen neueren Stand im Laufe des Jahrgangs, der in Punkt 3 angegeben ist.

Esempio:

Example:

Exemple

Beispiel:

005a.0 =
005 Gruppo Motore
a 10 HP TECUMSEH
.0 Prima stesura

005a.0 =
005 Engine unit
a 10 HP TECUMSEH
.0 First copy

005a.0 =
005 Groupe Moteur
a 10 HP TECUMSEH
.0 Première rédaction

005a.0 =
005 Motorgruppe
a 10 HP TECUMSEH
.0 Erste Ausgabe



← F72 • F72 hydro

2003

000.0

2 / 7

E. Numero della pagina e numero totale delle pagine necessarie per la descrizione del gruppo.

E. Page number and total number of pages necessary for the description of the unit.

E. Numéro de la page et nombre total des pages nécessaires pour la description du groupe.

E. Seitenzahl und Gesamtzahl der Seiten, die für die Beschreibung der Gruppe erforderlich sind.

F. Vista esplosa del gruppo.

F. Exploded view of the unit.

F. Vue éclatée du groupe.

F. Explosionszeichnung der Gruppe.

G. Descrizione completa dei singoli particolari, con codice e quantità di pezzi.

G. Full description of each part, with code number and number of pieces.

G. Description complète de chaque élément, avec code et quantité des pièces.

G. Vollständige Beschreibung der Einzelteile, mit Kodenummer und Menge der Teile.

H. Indicazione della presenza di altre pagine di seguito.

H. Indication of additional pages.

H. Indication de la présence d'autres pages successives.

H. Angabe über die Präsenz weiterer folgender Seiten.

Nelle pagine di seguito, sono riportate nuovamente le indicazioni relative ai punti A - C - D - E - G e H.

The additional pages repeat the indications as at points A - C - D - E - G and H.

Les pages qui suivent reportent, elles aussi, les indications concernant les points A - C - D - E - G et H.

Auf den nachfolgenden Seiten sind die Bezeichnungen, die sich auf die Punkte A - C - D - E - G und H beziehen, erneut wiedergegeben.

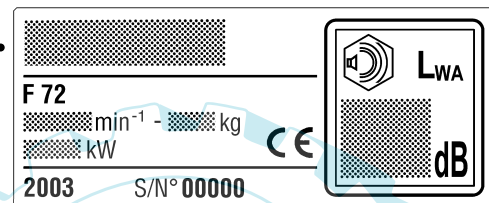
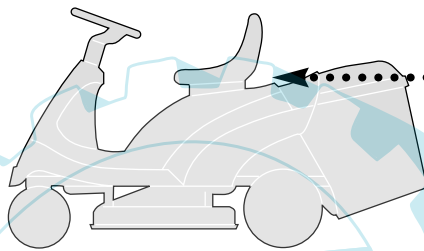

3. Ordine di ricambi

Prima di formulare un ordine di ricambi, accertare che il catalogo corrisponda all'anno di costruzione della macchina, e riportato sulla targhetta di identificazione.

Ogni ordine di ricambi deve necessariamente contenere:

- modello della macchina;
- quantità di pezzi richiesta;
- descrizione (eventuale);
- numero di codice del pezzo;
- destinatario
- mezzo di spedizione.

Esempio di ordinazione:

Su una macchina F72 del 2003, con motore TECUMSEH da 10 HP si deve sostituire la protezione del silenziatore. Tale particolare è raffigurato nella tavola **005a.0** alla posizione **22**, a cui corrisponde il codice **82598061/0**.

L'ordinazione sarà quindi:

per F72:
n. 1 protezione cod. 82598061/0 da inviare a
a mezzo

Nota

Per le parti non codificate del motore e della trasmissione contrassegnate con (*), occorre rivolgersi al Costruttore.

3. Spare parts order

Before putting in an order for spare parts, make sure that the catalogue is the one applying to the machine's year of manufacture, as shown on the identification plate attached to the machine.

Each spare parts order must include:

- the model of the machine;
- the number of parts required;
- description (incidental);
- the code number for the item;
- the destination;
- the method of shipping.

An example of an order:

The muffler protection on a F72 machine, produced in 2003 with an TECUMSEH 10 HP engine, must be replaced. This part is shown in table **005a.0** in position **22**, and has the code number **82598061/0**.

The order will therefore be:

for F72:
1 protection - code 82598061/0 to be sent to
method of shipping

Note

For parts of the engine and the transmission without code numbers, marked by (*), it's necessary to contact the manufacturer.

3. Commande pièces détachées

Avant de passer une commande pour des pièces détachées, s'assurer que le catalogue est celui correspondant à l'année de fabrication de la machine reportée sur la plaquette d'identification.

Chaque commande de pièces détachées doit obligatoirement contenir:

- modèle de la machine;
- quantité de pièces demandée;
- description (éventuelle);
- numéro de code de la pièce;
- le destinataire;
- le moyen de transport.

Exemple de commande:

Sur une machine F72 du 2003, avec moteur TECUMSEH de 10 CH, il faut remplacer la protection silencieux. Cette pièce est représentée sur le tableau **005a.0** à la position **22**, correspondant au code **82598061/0**.

La commande sera donc formulée de la façon suivante:

pour F72:
1 protection - code 82598061/0 à envoyer à
par

Remarque

Pour les pièces non codées du moteur et de la transmission, indiquées avec (*), il faut s'adresser au Fabricant.

3. Ersatzteilbestellungen

Ehe eine Ersatzteilbestellung geschrieben wird, muß man sich vergewissern, daß der Katalog mit dem Herstellungsjahr der Maschine übereinstimmt, oder mit dem auf dem Kennzeichenschild wiedergegeben.

Jede Ersatzteilbestellung muß enthalten:

- Modell der Maschine;
- Menge der angeforderten Teile;
- Bezeichnung (eventuell);
- Artikelnummer des Teils;
- Empfänger;
- Versandart.

Beispiel einer Bestellung:

Auf einer Maschine F72 von 2003, mit Motor TECUMSEH mit 10 PS muß der Auspuffschutz ersetzt werden. Dieses Einzelteil ist auf der Tafel **005a.0** unter der Position **22**, dargestellt, der dem Code **82598061/0** entspricht.

Die Bestellung lautet demnach:

Für F72:
1 Schutz - Kode 82598061/0 zu versenden an
mit

Anmerkung

Für die nicht codierten Teile des Motors und des Antriebs, die mit (*) gekennzeichnet sind, muß man sich an den Hersteller wenden.

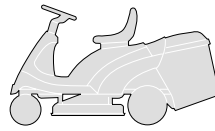





F72**F72 hydro**

INDICE DELLE TAVOLE
INDEX OF TABLES
SOMMAIRE DES TABLEAUX
INHALT DER TAFELN

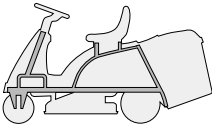
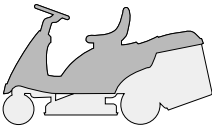
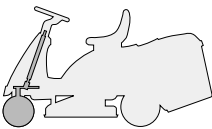
2003

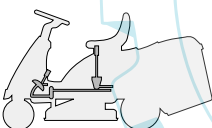
000.0

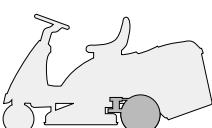
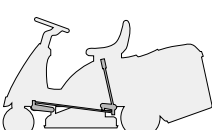
3 / 7

GRUPPO / UNIT / GROUPE / GRUPPE	F72	F72 hydro
 <p>TELAIO CHASSIS CHASSIS RAHMENSATZ</p>	001	001
 <p>CORROZZERIA BODY CARROSSERIE KARROSSERIE</p>	002	002
 <p>STERZO STEERING BARRE DE DIRECTION LENKGETRIEBE</p>	003	003
 <p>COMANDO FRENO E COMANDO CAMBIO BRAKE AND GEARBOX CONTROLS COMMANDE FREIN ET BOITE DE VITESSE BREMSE UND WECHSEL ANTRIEB</p>	004M	-
 <p>COMANDO TRASMISSIONE E FRENO DRIVE AND BRAKE CONTROLS COMMANDE TRANSMISSION ET FREIN GETRIEBE UND BREMSE ANTRIEB</p>	-	004Y
 <p>MOTORE ENGINE MOTEUR MOTOR 10 - 10,5 - 11 - 11,5 - 12 - 12,5 HP B&S</p>	005 005a	005 005a
 <p>TRASMISSIONE TRANSMISSION TRANSMISSION GETRIEBE</p>	006M	006Y
 <p>SOLLEVAMENTO PIATTO DI TAGLIO CUTTING PLATE LIFTING SOULEVEMENT PLATEAU DE COUPE SCHNEIDWERKZEUG AUFHEBESATZ</p>	007	007
 <p>PIATTO DI TAGLIO (1) CUTTING PLATE (1) PLATEAU DE COUPE (1) SCHNEIDWERKZEUG (1)</p>	008	008



← F72 • F72 hydro

2003

000.0

4 / 7

GRUPPO / UNIT / GROUPE / GRUPPE	F72	F72 hydro
---------------------------------	-----	-----------

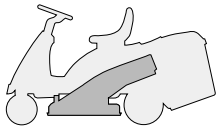

PIATTO DI TAGLIO (2)
 CUTTING PLATE (2)
 PLATEAU DE COUPE (2)
 SCHNEIDWERKZEUG (2)

009

009

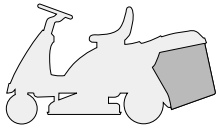

SACCO
 GRASSCATCHER
 BAC
 AUFFANGSACK

010

010

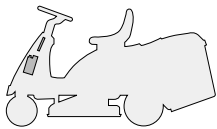

PARTI ELETTRICHE
 ELECTRICAL PARTS
 PARTIES ELECTRIQUES
 ELETRISCHETEILE

011

011



ACCESSORI A RICHIESTA
 OPTIONALS ON REQUEST
 ACCESSOIRES SUR DEMANDE
 ZUBEHOERE NACH ANFRAGE.....

012

012



ETICHETTE
 LABELS
 ETIQUETTES
 KLEBZETTEL

013

013

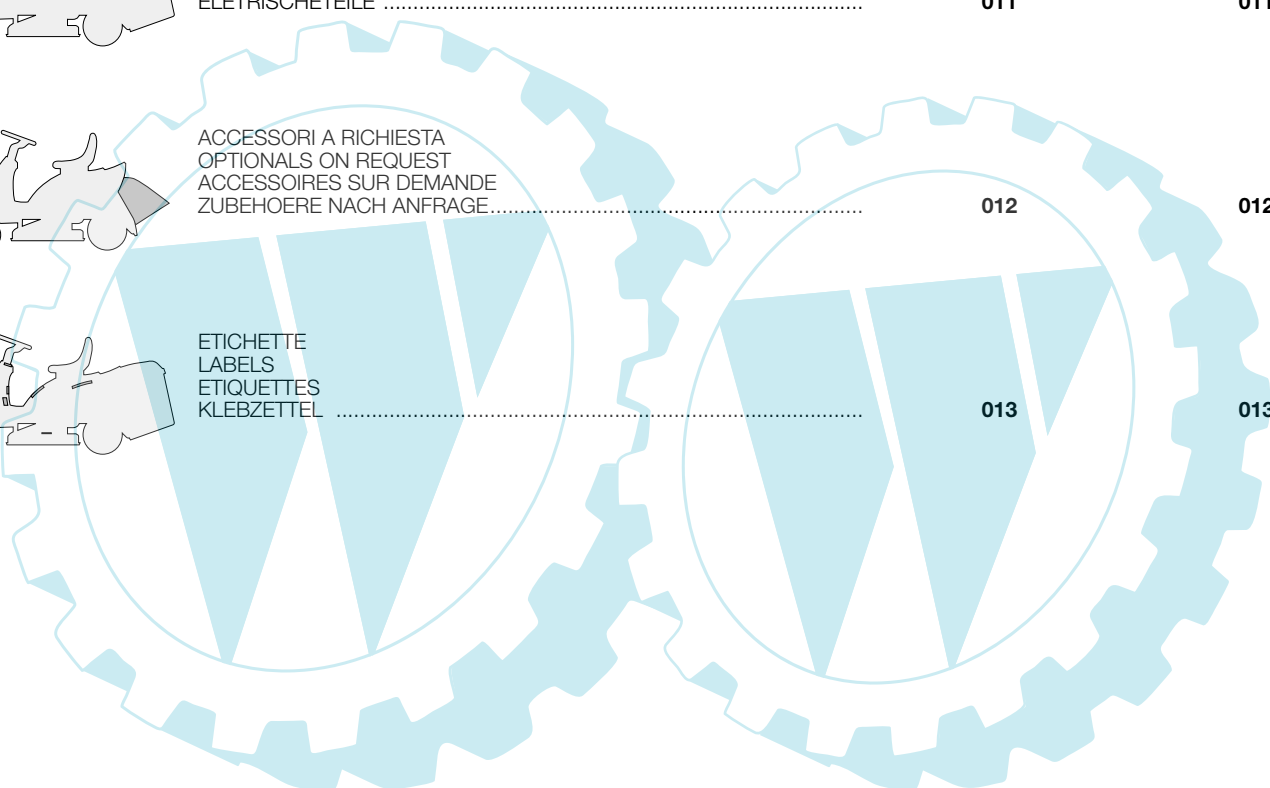

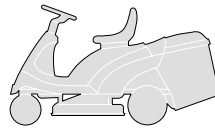
F72**F72 hydro**

ELENCO NUMERICO
NUMERICAL LIST
LISTE NUMERIQUE
NUMERISCHE AUFSTELLUNG

2003

000.0

5 / 7

CODE	TABLE	N.	Q.TY	CODE	TABLE	N.	Q.TY	CODE	TABLE	N.	Q.TY
12000955/0	001	54	2	12292102/0	005a	25	1	12523060/0	001	23	1
12001000/0	003	9	2	12292102/0	010	17	1	12523060/0	002	56	4
12001000/0	003	25	2	12293200/0	004M	14	1	12523060/0	004Y	39	1
12001000/0	003	56	2	12293200/0	004M	25	2	12523060/0	006M	13	1
12001010/0	006M	56	2	12293200/0	004M	51	1	12523060/0	006M	32	1
12001010/0	006Y	66	2	12293200/0	004Y	14	1	12523060/0	006Y	13	1
12139100/0	009	19	1	12293200/0	004Y	25	2	12523060/0	008	34	1
12139430/0	006M	22	1	12293200/0	004Y	73	1	12523060/0	008	40	1
12139480/0	009	25	1	12293200/0	004Y	87	2	12523070/0	002	21	2
12154210/0	006M	27	4	12293200/0	005	5	1	12523070/0	008	36	1
12154210/0	006Y	24	4	12293200/0	005a	5	1	12523080/0	009	22	1
12154210/0	009	17	4	12293200/0	006M	17	2	12523080/0	009	34	2
12154250/0	009	35	1	12293200/0	007	21	1	12523100/0	003	28	2
12154320/0	012	13	4	12293200/0	008	19	1	12540040/0	004M	53	1
12154330/0	002	67	2	12293200/0	008	22	1	12540040/0	010	16	1
12154330/0	002	70	1	12293200/0	008	68	1	12540260/0	005	6	2
12154330/0	006Y	52	1	12293201/0	001	10	4	12540260/0	005	10	1
12154510/0	002	17	2	12293201/0	001	13	4	12540260/0	005a	6	2
12154510/0	002	86	2	12293201/0	001	17	4	12540260/0	006M	8	1
12154510/0	004M	21	1	12293201/0	001	36	4	12540260/0	006Y	8	1
12154510/0	004Y	21	1	12293201/0	002	84	6	12543000/0	006M	3	1
12154510/0	005a	20	1	12293201/0	004M	33	1	12543000/0	006Y	3	1
12154510/0	006Y	45	2	12293201/0	004Y	61	1	12581200/0	002	43	2
12154510/0	007	30	1	12293201/0	005	4	3	12582100/0	006Y	34	1
12154510/0	008	12	2	12293201/0	005a	4	3	12582101/0	010	10	4
12154510/0	009	8	6	12293201/0	006M	33	1	12583500/0	002	55	4
12154510/0	009	32	4	12293201/0	008	41	1	12583500/0	003	12	1
12154510/0	010	14	2	12295200/0	007	15	1	12583500/0	004M	50	1
12154510/0	012	6	2	12295200/0	009	37	1	12583500/0	005a	15	2
12154510/0	012	9	1	12295300/0	003	30	1	12583500/0	008	21	1
12155000/0	001	24	1	12360352/0	011	11	2	12583500/0	009	28	1
12155000/0	002	22	2	12361005/0	011	23	1	12585100/0	009	39	1
12155000/0	004M	5	2	12379511/0	001	26	1	12587100/0	003	29	1
12155000/0	004M	26	1	12379511/0	003	22	2	12608600/0	004M	36	1
12155000/0	004M	41	1	12379511/0	004Y	53	1	12608950/0	006M	23	1
12155000/0	004M	48	1	12400030/0	010	34	1	12609260/0	009	14	1
12155000/0	004Y	5	2	12436030/0	003	6	1	12620299/0	002	62	1
12155000/0	004Y	27	1	12436050/0	007	23	1	12622650/0	003	3	1
12155000/0	004Y	58	1	12437502/0	002	75	2	12674550/0	006Y	44	2
12155000/0	004Y	92	1	12437503/0	002	13	2	12674700/0	007	29	1
12155000/0	006M	14	1	12500030/0	009	4	1	12674701/0	010	12	2
12155000/0	006M	18	1	12500090/0	001	25	1	12674701/0	012	5	2
12155000/0	006M	20	1	12520010/0	006M	57	2-4	12691100/0	005	3	1
12155000/0	006M	35	1	12520010/0	006Y	67	0-4	12691100/0	005a	3	1
12155000/0	006Y	14	1	12520031/0	003	10	0-2	12691200/0	002	20	2
12155000/0	006Y	29	1	12521320/0	002	74	2	12691200/0	008	33	1
12155000/0	007	22	1	12521330/0	004Y	54	1	12691600/0	008	39	1
12155000/0	007	26	1	12521330/0	004Y	83	2	12691800/0	006M	25	4
12155000/0	008	6	1	12521331/0	001	19	2	12691800/0	006Y	22	4
12155000/0	008	20	1	12521331/0	002	28	4	12692050/0	004M	40	1
12155000/0	008	37	1	12521331/0	010	13	2	12692050/0	004Y	57	1
12155000/0	008	69	1	12521340/0	009	31	4	12692050/0	008	5	1
12155000/0	008	71	1	12521350/0	001	35	2	12692695/0	003	27	1
12155000/0	011	21	1	12521350/0	003	31	1	12726388/0	002	45	1
12155000/0	012	24	3	12521350/0	004M	17	2	12726388/0	006Y	41	1
12155000/0	012	47	1	12521350/0	004Y	17	2	12727810/0	011	3	2
12155010/0	004Y	40	1	12521350/0	006M	34	1	12728460/0	002	73	2
12155010/0	004Y	75	1	12521350/0	006Y	28	1	12728510/0	010	35	3
12155010/0	004Y	89	1	12521350/0	008	17	1	12728510/0	010	38	4
12155010/0	006M	11	1	12521370/0	003	5	1	12729601/0	002	27	4
12155010/0	006Y	11	1	12521370/0	004M	35	2	12729601/0	010	8	4
12155010/0	008	65	1	12521370/0	006Y	31	1	12731350/0	004M	7	4
12155020/0	004Y	43	1	12521410/0	006M	54	2	12731350/0	004Y	7	4
12155020/0	004Y	52	1	12521410/0	006Y	64	2	12731350/0	007	3	4
12156602/0	003	19	4	12523020/0	002	66	2	12731350/0	007	10	4
12156602/0	007	6	1	12523020/0	006Y	48	1	12731601/0	004M	10	4
12156602/0	007	13	1	12523020/0	006Y	51	1	12731601/0	004Y	10	4
12156602/0	007	16	1	12523020/0	012	12	4	12731601/0	005a	23	1
12156602/0	009	38	1	12523040/0	001	43	1	12731601/0	008	8	4
12290800/0	002	46	1	12523040/0	002	11	2	12734995/0	001	18	2
12290800/0	006Y	42	1	12523040/0	002	16	4	12735104/0	005	11	1
12291000/0	006Y	49	1	12523040/0	009	7	6	12735106/0	001	48	2
12292100/0	010	11	4	12523050/0	004M	20	1	12735106/0	005a	17	4
12292102/0	001	7	8	12523050/0	004Y	20	1	12735110/0	001	40	1
12292102/0	004Y	84	2	12523050/0	006Y	32	1	12735110/0	001	46	2



 **F72 • F72 hydro**

2003

000.0

6 / 7

CODE	TABLE	N.	Q.TY	CODE	TABLE	N.	Q.TY	CODE	TABLE	N.	Q.TY
12735110/0	004Y	48	2	18565351/0	011	7	1	25510007/1	009	36	1
12735110/0	005	20	2	18566113/0	012	4	2	25510022/0	012	14	2
12735110/0	005a	27	2	18736110/0	011	9	1	25510040/1	004M	46	1
12735110/0	011	10	2	18737849/0	005	13	1	25510040/1	004Y	72	1
12735120/0	001	42	1	18737849/0	005a	8	1	25510040/1	004Y	86	1
12735150/0	006M	29	2	18738216/0	005a	16	1	25510040/1	006M	16	1
12735150/0	006Y	26	1	18738218/0	005a	13	1	25510040/1	007	20	1
12735402/0	002	9	10	19035000/0	009	3	1	25510040/1	008	67	1
12735402/0	002	24	4	19216032/0	009	12	2	25519997/1	012	22	1
12735402/0	002	26	2	19410605/1	011	14	1	25547012/1	001	5	2
12735402/0	009	53	8	19410606/0	011	13	4	25547033/1	002	53	1
12735410/0	002	10	8	22041980/0	008	62	1	25547049/0	004M	9	2
12735510/0	005	9	1	22110230/0	003	57	2	25547049/0	004Y	9	2
12735520/0	004M	52	1	22110230/0	006M	58	2	25547049/0	008	7	2
12735520/0	006Y	33	1	22110230/0	006Y	68	2	25547049/0	012	10	2
12735598/0	002	12	2	22160400/0	009	21	1	25547053/0	012	7	1
12735694/0	009	23	1	22171001/0	004M	18	1	25600020/0	002	71	1
12737310/0	006M	2	1	22171001/0	004Y	18	1	25600021/1	002	72	1
12737310/0	006Y	2	1	22399801/0	006Y	40	1	25600041/0	010	31	1
12737450/0	005a	14	2	22446402/0	006Y	15	1	25600042/0	010	32	1
12760520/0	012	23	3	226272151/0	004Y	35	2	25600047/0	010	36	1
12788512/0	002	42	2	226272151/0	006M	9	1	25600048/0	010	37	1
12788910/0	012	11	4	226272151/0	006Y	9	1	25601554/0	006M	12	1
12789000/0	002	69	1	226272152/0	004Y	38	1	25601554/0	006Y	12	1
12789100/0	002	65	2	226272152/0	008	35	1	25670005/1	003	55	2
12789100/0	006Y	47	1	226272152/0	008	63	1	25670005/1	006M	55	2
12790780/0	005a	24	1	226272152/0	012	46	1	25670005/1	006Y	65	2
12790780/0	010	15	1	22680009/0	004M	54	1	25670006/0	008	25	1
12791200/0	001	6	8	22746600/0	003	17	4	25670007/0	009	27	1
12791200/0	002	15	2	22746601/0	004M	44	1	25670008/1	001	53	4
12791200/0	008	11	2	22746601/0	008	14	1	25670008/1	004Y	51	1
12791400/0	004Y	82	2	22943005/0	004M	24	1	25670008/1	007	5	1
12791500/0	012	8	1	22943005/0	004Y	24	1	25670008/1	007	7	2
12792099/0	010	9	2	24487997/0	002	58	1	25670008/1	007	12	2
12792611/0	001	9	4	24487997/0	004M	22	1	25670008/1	007	17	2
12792611/0	001	12	4	24487997/0	004M	49	1	25670008/1	008	23	1
12792611/0	001	16	4	24487997/0	004Y	22	1	25670011/0	004M	47	2
12793101/0	002	54	4	24487997/0	004Y	77	1	25670011/0	004Y	74	2
12793102/0	003	11	1	24487997/0	004Y	91	1	25670011/0	004Y	88	2
12793102/0	004M	32	1	24487997/0	007	4	1	25670011/0	006M	10	1
12793102/0	006M	30	1	24487997/0	007	18	1	25670011/0	006M	19	2
12793102/0	008	64	1	24487997/0	008	24	1	25670011/0	006Y	10	1
12793102/0	009	26	1	24487997/0	008	72	1	25670011/0	007	24	1
12793301/0	004M	4	2	24487997/0	009	55	2	25670011/0	007	25	2
12793301/0	004Y	4	2	24487998/0	012	15	2	25670011/0	008	70	2
12793301/0	004Y	60	1	25033060/0	009	2	1	25722415/0	011	2	1
12793301/0	006M	31	1	25034001/0	001	27	1	25722453/1	002	51	1
12793301/0	006Y	27	1	25034002/1	001	2	2	25774275/0	004M	19	1
12793701/0	005	2	3	25034002/1	003	21	4	25774275/0	004Y	19	1
12793701/0	005a	2	3	25038003/0	003	2	1	25795000/0	002	82	1
12794900/0	004Y	42	1	25065014/1	011	17	1	25840003/2	007	14	1
12794970/0	009	33	1	25110267/0	004Y	2	1	25840011/0	012	52	1
12815200/0	009	30	4	25110269/0	004M	2	1	25869004/0	005	15	1
12815210/0	009	6	6	25120230/0	002	63	1	25869027/0	005a	10	1
12815240/0	005a	19	1	25122000/1	001	37	2	25943050/0	001	34	2
12818700/0	009	15	4	25122200/2	003	53	4	25950000/0	006M	59	2
12818700/0	012	44	1	25160012/0	006Y	43	2	25950000/0	006Y	69	2
14356699/0	013	10	2	25160016/0	003	26	1	25950002/0	003	58	2
14357423/1	013	9	1	25160501/0	009	13	1	25961201/0	002	61	1
14357425/0	013	3	1	25170600/0	006Y	50	1	27010205/0	010	4	1
14357426/0	013	7	1	25253004/0	012	53	3	27010207/0	010	5	1
14357427/0	013	6	1	25280000/1	012	51	1	27023000/0	009	10	1
14357428/0	013	1	1	25318124/0	010	33	1	27034052/0	004M	43	1
14357431/0	013	4	1	25394501/0	002	44	1	27034054/0	006M	15	1
14357519/1	013	2	1	25394510/0	007	28	1	27034056/0	002	85	1
14357526/0	013	5	1	25394510/0	008	2	1	27034058/0	004Y	85	1
14357702/0	013	8	1	25430210/0	004M	23	1	27034059/0	004M	13	1
18120002/1	011	19	1	25430210/0	004Y	23	1	27034060/0	004Y	13	1
18210016/0	011	8	1	25430223/1	002	68	1	27034062/0	004Y	71	1
18375051/1	005	18	3	25430226/0	004M	39	1	27034077/0	008	66	1
18375051/1	005a	12	3	25430226/0	004Y	56	1	27034078/0	008	13	1
18375053/0	005	17	1	25430226/0	008	4	1	27037000/1	001	4	1
18375053/0	005a	11	1	25430229/1	012	50	1	27045000/0	009	5	1
18400861/0	011	6	1	25430236/0	004M	16	1	27045080/0	004Y	33	2
18400915/2	006M	24	1	25430236/0	004Y	16	1	27047000/0	008	32	1
18400936/0	006Y	21	1	25430571/0	008	9	1	27047002/0	004M	34	2
18401001/0	005	14	2	25430575/0	001	33	2	27047003/0	002	18	2
18401001/0	005a	9	2	25430576/0	008	16	1	27047012/0	001	51	2
18450065/1	011	5	1	25463200/0	009	18	1	27047013/0	012	45	1
18564861/1	011	22	1	25510007/1	007	11	1	27063020/0	004Y	47	2



 **F72 • F72 hydro**

2003

000.0

7 / 7

CODE	TABLE	N.	Q.TY	CODE	TABLE	N.	Q.TY	CODE	TABLE	N.	Q.TY
27063021/0	002	64	1	27772067/0	006M	28	2	84650100/0	010	7	1
27065050/0	011	18	1	27772095/0	001	47	1	84680050/0	006M	51	2
27107501/0	009	51	1	27772099/0	011	20	1	84680050/0	006Y	61	2
27109501/0	002	7	1	27772101/0	004Y	36	1	84680052/0	003	51	2
27109505/0	002	7	1	27772103/0	004Y	37	1	84680053/0	006M	51	2
27109506/0	002	7	1	27772105/0	004Y	81	1	84680053/0	006Y	61	2
27109507/0	002	7	1	27772115/0	006Y	25	1	84680055/0	003	51	2
27110302/1	002	4	1	27772143/0	008	15	1	84735551/0	003	7	1
27110303/0	002	5	1	27787025/0	001	15	2	84773551/0	004M	31	1
27110304/0	002	29	1	27840050/0	003	16	2	84773553/0	004M	38	1
27110305/0	002	30	1	27864052/0	002	57	1	84773557/0	005a	18	1
27110306/1	002	6	1	27869053/0	012	3	1	84773561/0	004Y	34	1
27110317/1	002	4	1	33320504/0	011	25	1	84773563/0	004Y	49	1
27110318/1	002	4	1	33320506/0	011	24	3	84773565/0	004Y	46	1
27110319/1	002	4	1	33340033/0	011	4	1	84773568/0	004Y	32	1
27110321/0	002	5	1	35061400/0	006M	5	1	84783005/2	002	83	1
27110322/0	002	5	1	35061403/0	006Y	5	1	84783009/0	001	11	1
27110323/0	002	5	1	35061423/0	008	42	1	84801103/0	010	1	1
27140051/1	009	52	1	82180050/0	012	31	1	84801105/0	010	2	1
27140054/0	012	43	1	82394508/0	004M	42	1	84801107/1	001	14	1
27140055/0	012	42	1	82394508/0	004Y	59	1	84801127/0	001	8	1
27158000/0	004Y	44	2	82598001/0	005	8	1	84801131/0	001	1	1
27208402/0	009	11	1	82601503/0	006M	21	1	84869051/0	010	6	1
27275000/0	004Y	26	1	84000250/0	002	41	1	99900030/6	012	21	1
27294001/0	001	41	1	84000501/0	003	8	1	99900036/0	012	41	1
27294002/0	001	45	1	84001005/1	007	8	1	99900090/0	012	1	1
27315077/0	004M	45	1	84001007/0	008	3	1				
27315119/0	006Y	30	1	84001011/2	004M	8	1				
27394003/1	012	48	1	84001011/2	004Y	8	1				
27395050/1	004M	12	1	84001015/1	004M	3	1				
27395050/1	004Y	12	1	84001015/1	004Y	3	1				
27430551/1	002	19	2	84001025/0	007	1	1				
27430552/0	004M	11	1	84002051/0	007	19	1				
27430552/0	004Y	11	1	84034057/0	003	20	1				
27430554/0	001	39	1	84040117/0	011	1	1				
27430555/0	007	31	1	84040300/0	001	20	1				
27430560/0	004Y	50	1	84040350/0	006Y	39	1				
27430562/0	005	21	1	84044000/0	003	52	2				
27430577/0	001	52	2	84044001/0	006M	52	1				
27487000/0	008	10	1	84044001/0	006Y	62	1				
27488000/0	009	29	1	84106050/0	010	3	1				
27510096/0	006M	7	1	84108051/0	009	56	1				
27510096/0	006Y	7	1	84109503/0	009	20	1				
27510097/1	009	54	1	84110100/2	002	8	1				
27510103/0	004M	15	1	84110102/2	002	8	1				
27510103/0	004Y	15	1	84110103/2	002	8	1				
27510113/0	008	18	1	84110104/2	002	8	1				
27510114/0	007	32	1	84110107/2	002	8	1				
27510116/0	012	49	2	84110109/2	002	8	1				
27520050/0	003	1	1	84110110/2	002	8	1				
27546001/0	002	23	2	84110111/2	002	8	1				
27546003/0	002	25	2	84110117/1	002	3	1				
27546009/0	005a	21	1	84110118/1	002	3	1				
27546015/1	004M	6	2	84110119/1	002	3	1				
27546015/1	004Y	6	2	84110120/1	002	3	1				
27546015/1	007	2	2	84180180/0	010	18	1				
27546015/1	007	9	2	84207101/1	004Y	80	1				
27546025/0	006Y	46	1	84207250/0	009	9	1				
27570050/0	003	4	1	84220501/0	008	61	1				
27590050/0	003	54	2	84230401/0	003	23	1				
27590051/0	006M	53	1	84230403/0	003	24	1				
27590051/0	006Y	63	1	84317051/2	004M	37	1				
27590052/0	003	54	2	84317051/2	004Y	55	1				
27590053/0	006M	53	1	84317055/0	006M	6	1				
27590053/0	006Y	63	1	84317065/1	007	27	1				
27598060/0	005	12	1	84317067/0	006Y	6	1				
27598060/0	005a	7	1	84317069/0	008	1	1				
27600059/1	005	19	1	84317083/0	008	31	1				
27600059/1	005a	26	1	84503001/0	004M	1	1				
27600091/0	002	2	1	84503001/0	004Y	1	1				
27600092/0	002	2	1	84545057/2	001	3	1				
27600093/0	002	2	1	84564097/0	009	1	1				
27600094/0	002	2	1	84564099/0	009	—	1				
27604003/1	006M	1	1	84598061/0	005a	22	1				
27604003/1	006Y	1	1	84598062/0	012	2	1				
27604008/0	008	38	1	84598064/0	002	1	1				
27604009/0	009	24	1	84598065/0	002	1	1				
27670053/0	004Y	45	2	84598066/0	002	1	1				
27733000/2	002	81	1	84598067/0	002	1	1				
27734055/0	004Y	41	1	84640550/0	005	7	1				

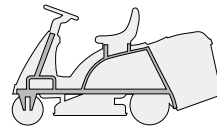

TAVOLE
TABLES
TABLEAUX
TAFELN

F72**F72 hydro**
TELAIO
CHASSIS
CHASSIS
RAHMENSATZ

2003

001.0

1 / 2

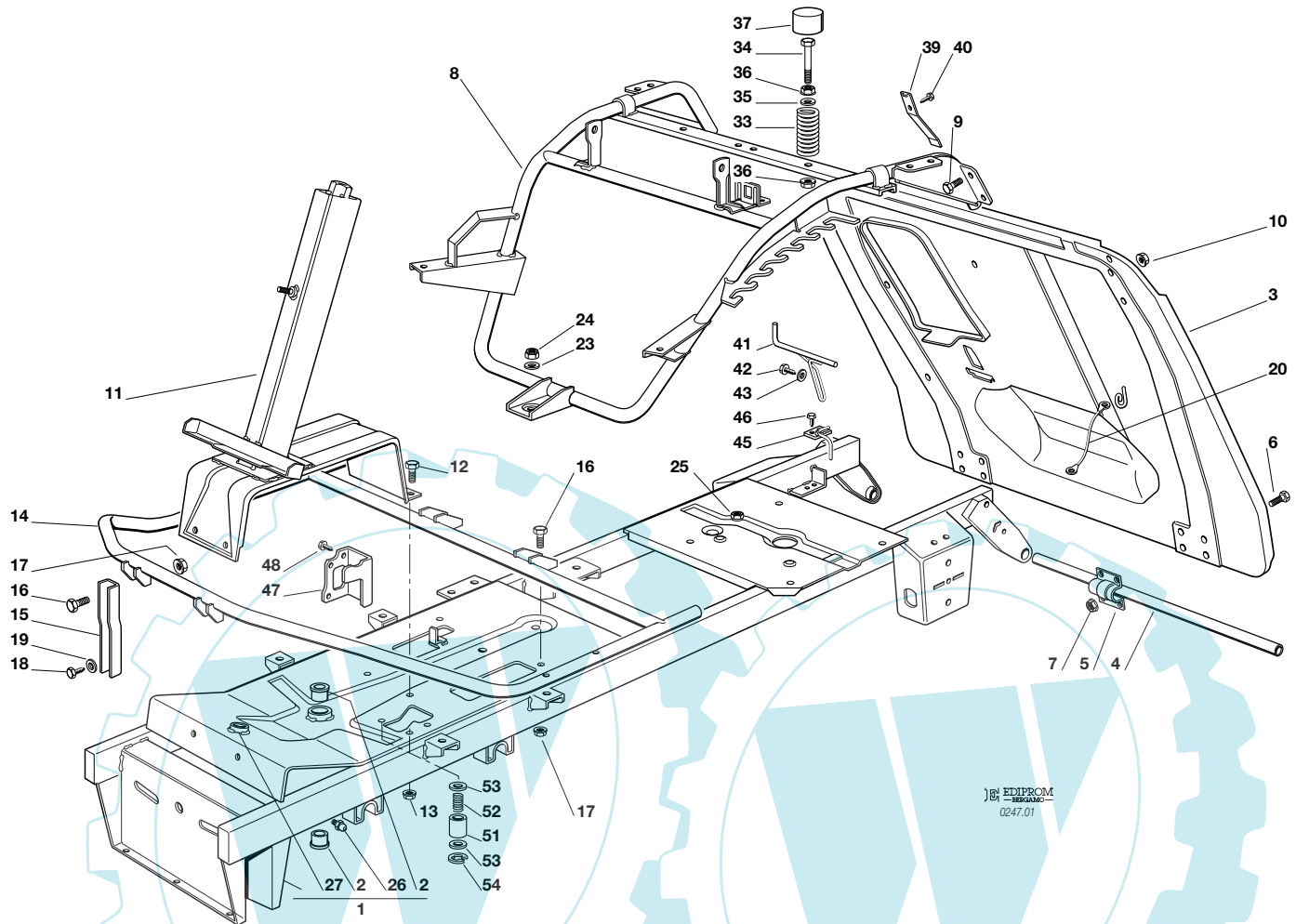
 EDIPROM
 - BERGAMO -
 0247.01

N.	CODE	Q.TY	DESCRIZIONE	DESCRIPTION	DESCRIPTION	BESCHREIBUNG
1	84801131/0	1	TELAIO	CHASSIS	CHASSIS	RAHMENSATZ
2	25034002/1	2	BOCCOLA	BUSH	DOUILLE	BÜCHSE
3	84545057/2	1	PIASTRA	PLATE	PLAQUE	PLATTE
4	27037000/1	1	PERNO	PIN	PIVOT	BOLZEN
5	25547012/1	2	PIASTRA	PLATE	PLAQUE	PLATTE
6	12791200/0	8	VITE	SCREW	VIS	SCHRAUBE
7	12292102/0	8	DADO	NUT	ECROU	MUTTER
8	84801127/0	1	TELAIO SEDILE	CHASSIS	CHASSIS	RAHMENSATZ
9	12792611/0	4	VITE	SCREW	VIS	SCHRAUBE
10	12293201/0	4	DADO	NUT	ECROU	MUTTER
11	84783009/0	1	SUPPORTO PIANTONE	SUPPORT	SUPPORT	HALTER
12	12792611/0	4	VITE	SCREW	VIS	SCHRAUBE
13	12293201/0	4	DADO	NUT	ECROU	MUTTER
14	84801107/1	1	SUPPORTO PEDANE	FOTTBOARD SUPPORT	SUPPORT MARCHEPIED	FUSSBRETTHALTER
15	27787025/0	2	SUPPORTO	SUPPORT	SUPPORT	HALTER
16	12792611/0	4	VITE	SCREW	VIS	SCHRAUBE
17	12293201/0	4	DADO	NUT	ECROU	MUTTER
18	12734995/0	2	VITE	SCREW	VIS	SCHRAUBE
19	12521331/0	2	RONDELLA	WASHER	RONDELLE	SCHEIBE
20	84040300/0	1	CAVO AGGANCIAMENTO	CORD	CORDE	SEIL
23	12523060/0	1	RONDELLA	WASHER	RONDELLE	SCHEIBE
24	12155000/0	1	DADO	NUT	ECROU	MUTTER
25	12500090/0	1	DADO	NUT	ECROU	MUTTER
26	12379511/0	1	INGRASSATORE	GREASE DISPENSER	GRAISSEUR	FETTBÜCHSE
27	25034001/0	1	BRONZINA	BUSH	DOUILLE	BÜCHSE
33	25430575/0	2	MOLLA	SPRING	RESSORT	FEDER
34	25943050/0	2	VITE	SCREW	VIS	SCHRAUBE
35	12521350/0	2	RONDELLA	WASHER	RONDELLE	SCHEIBE
36	12293201/0	4	DADO	NUT	ECROU	MUTTER
37	25122000/1	2	CUFFIA	HOOD	PROTECTEUR	SCHUTZKASTEN



 **F72 • F72 hydro**

2003

001.0

2 / 2

N.	CODE	Q.TY	DESCRIZIONE	DESCRIPTION	DESCRIPTION	BESCHREIBUNG
39	27430554/0	1	MOLLA	SPRING	RESSORT	FEDER
40	12735110/0	1	VITE	SCREW	VIS	SCHRAUBE
41	27294001/0	1	GUIDA	GUIDE	GUIDE	FÜHRUNG
42	12735120/0	1	VITE	SCREW	VIS	SCHRAUBE
43	12523040/0	1	RONDELLA	WASHER	RONDELLE	SCHEIBE
45	27294002/0	1	GUIDACINGHIA <i>(mecc.)</i>	BELT GUIDE <i>(mech.)</i>	GUIDE DE CURROIRE <i>(mec.)</i>	RIEMENFÜHRUNG <i>(mech.)</i>
46	12735110/0	2	VITE <i>(mecc.)</i>	SCREW <i>(mech.)</i>	VIS <i>(mec.)</i>	SCHRAUBE <i>(mech.)</i>
47	27772095/0	1	STAFFA	CLAMP	ETRIER	BRIDE
48	12735106/0	2	VITE	SCREW	VIS	SCHRAUBE
51	27047012/0	2	BUSSOLA	BUSH	DOUILLE	BÜCHSE
52	27430577/0	2	MOLLA	SPRING	RESSORT	FEDER
53	25670008/1	4	RONDELLA	WASHER	RONDELLE	SCHEIBE
54	12000955/0	2	ANELLO ELASTICO	SNAP RING	ANNEAU RESSORT	SPRENGRING

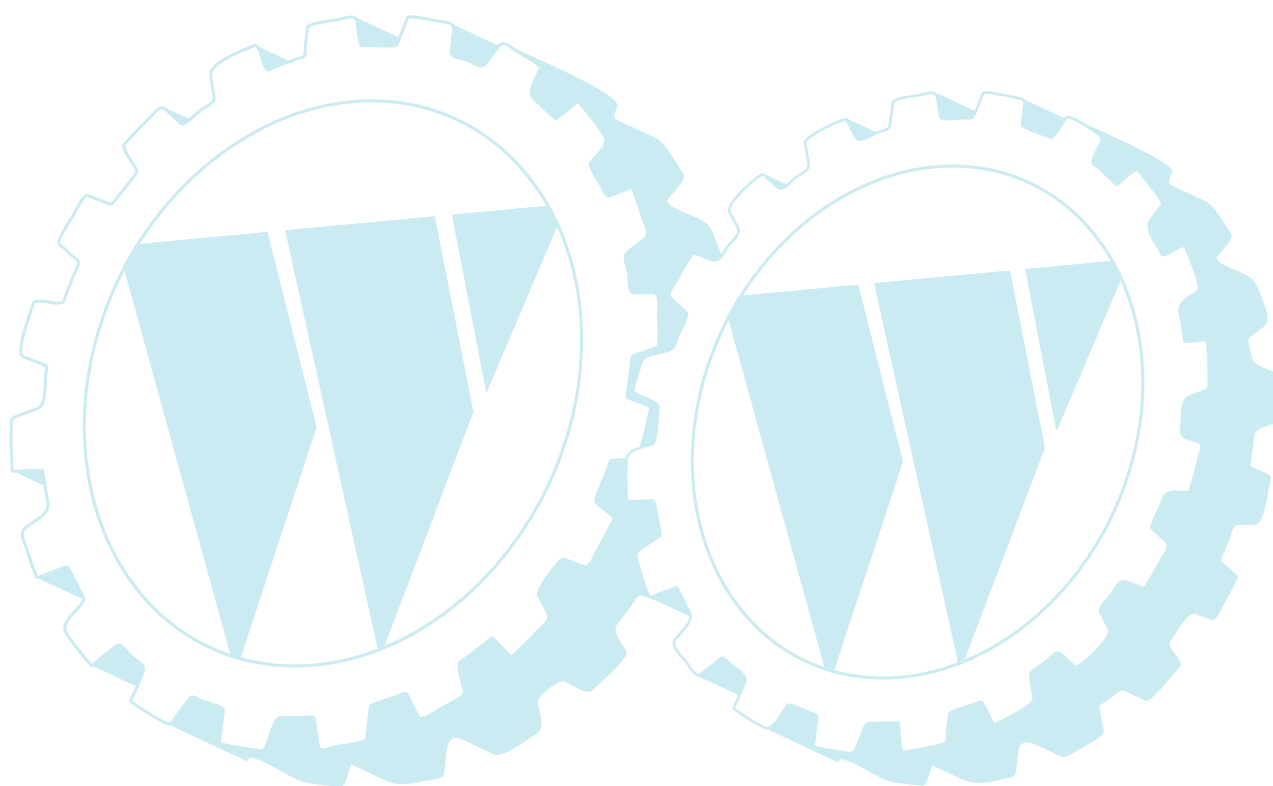

F72

F72 hydro

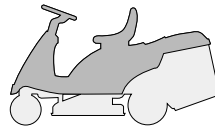

**CARROZZERIA
BODY
CARROSSERIE
KARROSSERIE**

2003

002.0

1 / 2

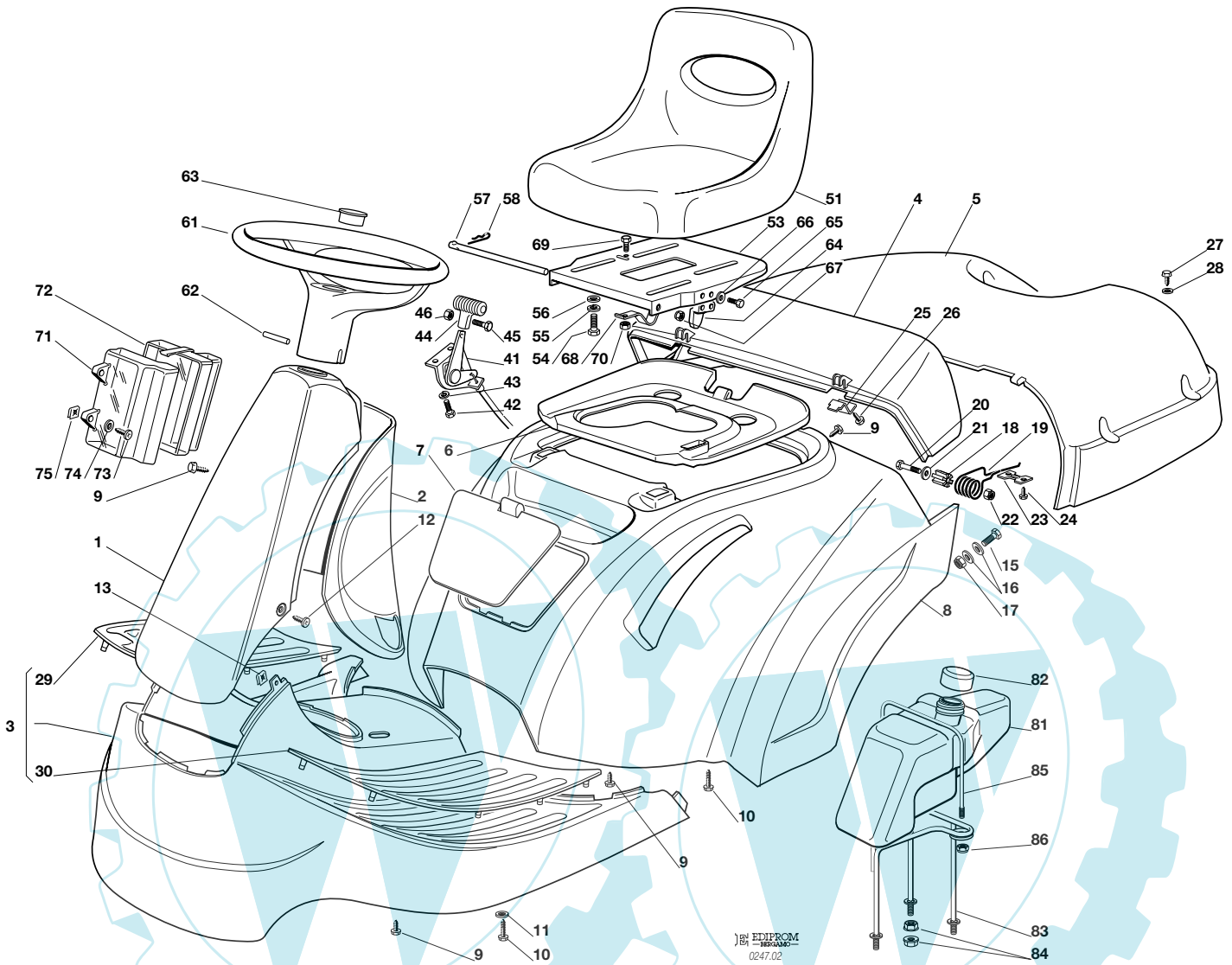

N.	CODE	Q.TY	DESCRIZIONE	DESCRIPTION	DESCRIPTION	BESCHREIBUNG
1	84598064/0 84598065/0 84598066/0 84598067/0	1	PROTEZIONE ANTERIORE ROSSO VERDE GIALLO BLU	FRONT COVER RED GREEN YELLOW BLUE	COUVERCLE AVANT ROUGE VERT JAUNE BLEU	VORDERDECKEL ROT GRÜN GELB BLAU
2	27600091/0 27600092/0 27600093/0 27600094/0	1	PROTEZIONE POSTERIORE ROSSO VERDE GIALLO BLU	REAR COVER RED GREEN YELLOW BLUE	COUVERCLE ARRIER ROUGE VERT JAUNE BLEU	HINTERDECKEL ROT GRÜN GELB BLAU
3	84110117/1 84110118/1 84110119/1 84110120/1	1	COPERTURA PEDANA ROSSO VERDE GIALLO BLU	FOOTBOARD COVER RED GREEN YELLOW BLUE	COUVRE MARCHEPIED ROUGE VERT JAUNE BLEU	FUSSBRETTDECKEL ROT GRÜN GELB BLAU
4	27110302/1 27110317/1 27110318/1 27110319/1	1	COPERTURA SACCO FISSA ROSSO VERDE GIALLO BLU	GRASS-CATCHER COVER, FIXED RED GREEN YELLOW BLUE	COUVRE-BAC FIXE ROUGE VERT JAUNE BLEU	FESTER SACKKAPPE ROT GRÜN GELB BLAU
5	27110303/0 27110321/0 27110322/0 27110323/0	1	COPERTURA SACCO MOBILE ROSSO VERDE GIALLO BLU	GRASS-CATCHER COVER, MOBILE RED GREEN YELLOW BLUE	COUVRE-BAC MOBILE ROUGE VERT JAUNE BLEU	BEWEGLICHER SACKKAPPE ROT GRÜN GELB BLAU
6	27110306/1	1	COPERTURA MOTORE	ENGINE COVER	COUVRE MOTEUR	MOTORKAPPE



 **F72 • F72 hydro**

2003

002.0

2 / 2

N.	CODE	Q.TY	DESCRIZIONE	DESCRIPTION	DESCRIPTION	BESCHREIBUNG
7	27109501/0 27109505/0 27109506/0 27109507/0	1	COPERCHIO ANTERIORE ROSSO VERDE GIALLO BLU	FRONT COVER RED GREEN YELLOW BLUE	COUVERCLE AVANT ROUGE VERT JAUNE BLEU	DECKEL ROT GRÜN GELB BLAU
8	84110100/2 84110102/2 84110103/2 84110104/2	1	COPERTURA RUOTE ROSSO VERDE GIALLO BLU	WHEELS COVER RED GREEN YELLOW BLUE	COUVRE ROUES ROUGE VERT JAUNE BLEU	RADENKAPPE ROT GRÜN GELB BLAU
8	84110107/2 84110109/2 84110110/2 84110111/2	1	COPERTURA RUOTE (hydro) ROSSO VERDE GIALLO BLU	WHEELS COVER (hydro) RED GREEN YELLOW BLUE	COUVRE ROUES (hydro) ROUGE VERT JAUNE BLEU	RADENKAPPE (hydro) ROT GRÜN GELB BLAU
9	12735402/0	10	VITE	SCREW	VIS	SCHRAUBE
10	12735410/0	8	VITE	SCREW	VIS	SCHRAUBE
11	12523040/0	2	RONDELLA	WASHER	RONDELLE	SCHEIBE
12	12735598/0	2	VITE	SCREW	VIS	SCHRAUBE
13	12437503/0	2	PIASTRINA	PLATE	PLAQUE	PLATTE
15	12791200/0	2	VITE	SCREW	VIS	SCHRAUBE
16	12523040/0	4	RONDELLA	WASHER	RONDELLE	SCHEIBE
17	12154510/0	2	DADO	NUT	ECROU	MUTTER
18	27047003/0	2	BUSSOLA	BUSH	DOUILLE	BUCHSE
19	27430551/1	2	MOLLA	SPRING	RESSORT	FEDER
20	12691200/0	2	VITE	SCREW	VIS	SCHRAUBE
21	12523070/0	2	RONDELLA	WASHER	RONDELLE	SCHEIBE
22	12155000/0	2	DADO	NUT	ECROU	MUTTER
23	27546001/0	2	PIASTRINA	PLATE	PLAQUE	PLATTE
24	12735402/0	4	VITE	SCREW	VIS	SCHRAUBE
25	27546003/0	2	PIASTRINA	PLATE	PLAQUE	PLATTE
26	12735402/0	2	VITE	SCREW	VIS	SCHRAUBE
27	12729601/0	4	VITE	SCREW	VIS	SCHRAUBE
28	12521331/0	4	RONDELLA	WASHER	RONDELLE	SCHEIBE
29	27110304/0	1	COPRIPEDANA DESTRA	RIGHT FOOTBOARD COVER	COUVRE MARCHEPIED DRO.	RECHTE FUSSBRETTDECKEL
30	27110305/0	1	COPRIPEDANA SINISTRA	LEFT FOOTBOARD COVER	COUVRE MARCHEPIED GAU.	LINKE FUSSBRETTDECKEL
41	84000250/0	1	ACCELERATORE	ACCELERATOR	ACCELERATEUR	GAS ZUG
42	12788512/0	2	VITE	SCREW	VIS	SCHRAUBE
43	12581200/0	2	GROWER	GROWER	GROWER	GROWER
44	25394501/0	1	MANOPOLINA	HANDLE	POIGNE	GRIFF
45	12726388/0	1	VITE	SCREW	VIS	SCHRAUBE
46	12290800/0	1	DADO	NUT	ECROU	MUTTER
51	25722453/1	1	SEDILE	SEAT	SIEGE	SITZ
53	25547033/1	1	PIASTRA	PLATE	PLAQUE	PLATTE
54	12793101/0	4	VITE	SCREW	VIS	SCHRAUBE
55	12583500/0	4	GROWER	GROWER	GROWER	GROWER
56	12523060/0	4	RONDELLA	WASHER	RONDELLE	SCHEIBE
57	27864052/0	1	PERNO	PIN	PIVOT	BOLZEN
58	24487997/0	1	COPPIGLIA	COTTER PIN	GOUPILLE	SPLIT
61	25961201/0	1	VOLANTE	STEERING WHEEL	VOLANT	LENKRAD
62	12620299/0	1	SPINA	PIN	GOUPILLE	STIFT
63	25120230/0	1	TAPPO	CAP	BOUCHON	STOPFEN
64	27063021/0	1	CAMMA	CAM	CAME	NOCKEN
65	12789100/0	2	VITE	SCREW	VIS	SCHRAUBE
66	12523020/0	2	RONDELLA	WASHER	RONDELLE	SCHEIBE
67	12154330/0	2	DADO	NUT	ECROU	MUTTER
68	25430223/1	1	MOLLA	SPRING	RESSORT	FEDER
69	12789000/0	1	VITE	SCREW	VIS	SCHRAUBE
70	12154330/0	1	DADO	NUT	ECROU	MUTTER
71	25600020/0	1	PROTEZIONE SUPERIORE	UPPER GUARD	PROTECTION SUPERIEUR	OBERSCHUTZ
72	25600021/1	1	PROTEZIONE INFERIORE	LOWER GUARD	PROTECTION INFERIEUR	UNTERSCHUTZ
73	12728460/0	2	VITE	SCREW	VIS	SCHRAUBE
74	12521320/0	2	ROSETTA	WASHER	RONDELLE	SCHEIBE
75	12437502/0	2	PIASTRINA	PLATE	PLAQUE	PLÄTTE
81	27733000/2	1	SERBATOIO	TANK	RESERVOIR	TANK
82	25795000/0	1	TAPPO	CAP	BOUCHON	TANKVERSCHLUSS
83	84783005/2	1	SUPPORTO	SUPPORT	SUPPORT	HALTER
84	12293201/0	6	DADO	NUT	ECROU	MUTTER
85	27034056/0	1	ASTA	ROD	TIGE	STAB
86	12154510/0	2	DADO	NUT	ECROU	MUTTER

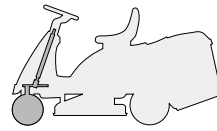
F72**F72 hydro**

STERZO
STEERING
BARRE DE DIRECTION
LENKGETRIEBE

2003

003.0

1 / 2

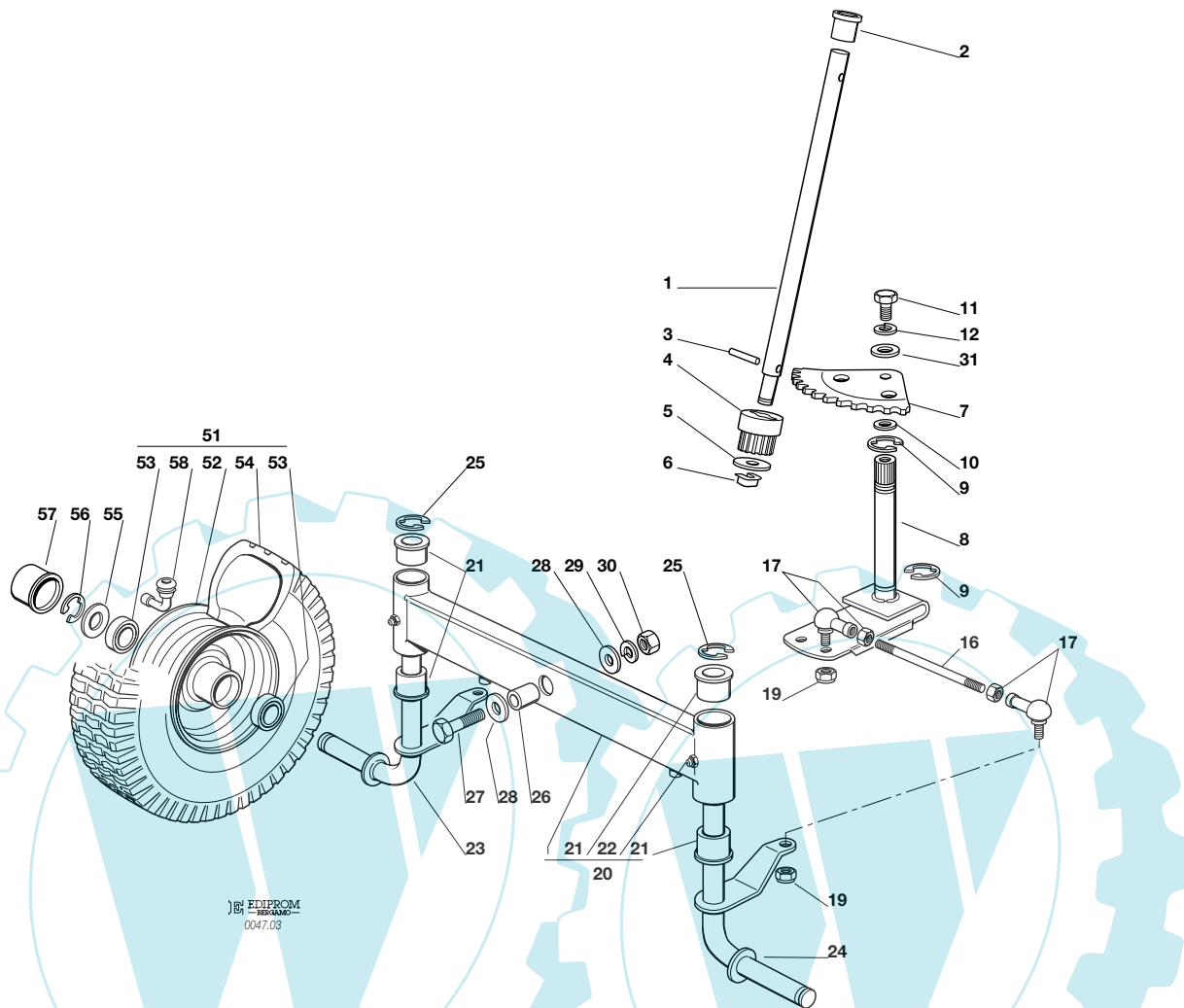

EDIPROM
 0047.03

N.	CODE	Q.TY	DESCRIZIONE	DESCRIPTION	DESCRIPTION	BESCHREIBUNG
1	27520050/0	1	PIANTONE	STEERING COLUMN	TUBE DE DIRECTION	LENKUNGSÄULE
2	25038003/0	1	BOCCOLA	BUSH	DOUILLE	BÜCHSE
3	12622650/0	1	SPINA	PIN	GOUPILLE	STIFT
4	27570050/0	1	PIGNONE	PINION	PIGNON	RITZEL
5	12521370/0	1	RONDELLA	WASHER	RONDELLE	SCHEIBE
6	12436030/0	1	PIASTRINA	PLATE	PLAQUETTE	PLATTECHEN
7	84735551/0	1	SETTORE	STEERING SHAFT	ARBRE DIRECTION	LENKUNGSWELLE
8	84000501/0	1	ALBERO STERZO	SHAFT	ARBRE	WELLE
9	12001000/0	2	ANELLO ELASTICO	SNAP RING	ANNEAU RESSORT	SPRENGRING
10	12520031/0	0-2	RONDELLA	WASHER	RONDELLE	SCHEIBE
11	12793102/0	1	VITE	SCREW	VIS	SCHRAUBE
12	12583500/0	1	GROWER	GROWER	GROWER	GROWER
16	27840050/0	2	TIRANTE COLLEG. FUSELLI	TIE ROD	TIRANT	SPANNSTANGE
17	22746600/0	4	SNODO	JOINT	JOINT	GELENK
19	12156602/0	4	DADO	NUT	ECROU	MUTTER
20	84034057/0	1	BILANCIERE COMPLETO DI BOCCOLA ED INGRASSATORE	EQUALIZER WITH BUSH AND LUBRICATOR	BALANCIER AVEC DOULIE ET GRAISSEUR	KIPPHEBEL MIT BÜCHSE UND FETTBUCHSE
21	25034002/1	4	BOCCOLA	BUSH	DOUILLE	BÜCHSE
22	12379511/0	2	INGRASSATORE	GREASE DISPENSER	GRAISSEUR	FETTBUCHSE
23	84230401/0	1	FUSELLO DESTRO	RIGHT STUB AXLE	FUSEAU DROITE	RECHTER ACHSSCHENKEL
24	84230403/0	1	FUSELLO SINISTRO	LEFT STUB AXLE	FUSEAU GAUCHE	LINKER ACHSSCHENKEL
25	12001000/0	2	ANELLO ELASTICO	SNAP RING	ANNEAU RESSORT	SPRENGRING
26	25160016/0	1	DISTANZIALE	SPACER	ENTRETOISE	ENTFERNUNGSSTÜCK
27	12692695/0	1	VITE	SCREW	VIS	SCHRAUBE
28	12523100/0	2	RONDELLA	WASHER	RONDELLE	SCHEIBE
29	12587100/0	1	GROWER	GROWER	GROWER	GROWER
30	12295300/0	1	DADO	NUT	ECROU	MUTTER
31	12521350/0	1	RONDELLA	WASHER	RONDELLE	SCHEIBE



 **F72 • F72 hydro**

2003

003.0

2 / 2

N.	CODE	Q.TY	DESCRIZIONE	DESCRIPTION	DESCRIPTION	BESCHREIBUNG
51	84680052/0 84680055/0	2	RUOTA ANTERIORE TURF SAVER CARLISLE DELI TIRE	FRONT WHEEL TURF SAVER CARLISLE DELI TIRE	ROUE AVANT TURF SAVER CARLISLE DELI TIRE	VORDERRAD TURF SAVER CARLISLE DELI TIRE
52	84044000/0	2	CERCHIO RUOTA	RIMM	BANDAGE ROUE	VORDERRAD FELGER
53	25122200/2	4	CUSCINETTO	BEARING	ROULEMENT	LAGER
54	27590050/0 27590052/0	2	PNEUMATICO TURF SAVER CARLISLE DELI TIRE	SHOE TURF SAVER CARLISLE DELI TIRE	PNEU TURF SAVER CARLISLE DELI TIRE	REIFEN TURF SAVER CARLISLE DELI TIRE
55	25670005/1	2	RONDELLA	WASHER	RONDELLE	SCHEIBE
56	12001000/0	2	ANELLO ELASTICO	SNAP RING	ANNEAU RESSORT	SPRENGRING
57	22110230/0	2	COPRIMOZZO	HUB COVER	COUVRE MOYEU	NABEDECKEL
58	25950002/0	2	VALVOLA	VALVE	SOUPAPE	VENTIL

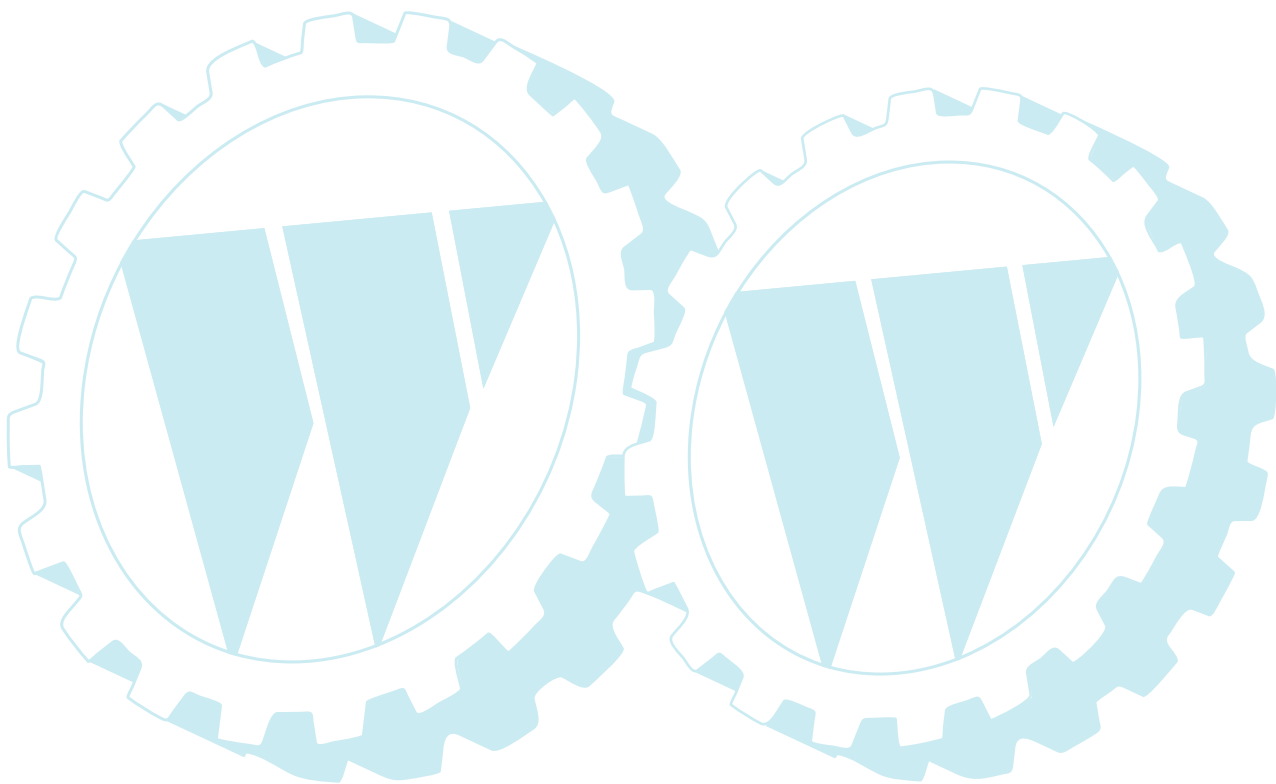

F72

F72 hydro

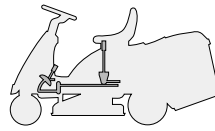

COMANDO FRENO E COMANDO CAMBIO
BRAKE AND GEARBOX CONTROLS
COMMANDE FREIN ET BOITE DE VITESSE
BREMSE UND WECHSEL ANTRIEB

2003

004M.0

1 / 2

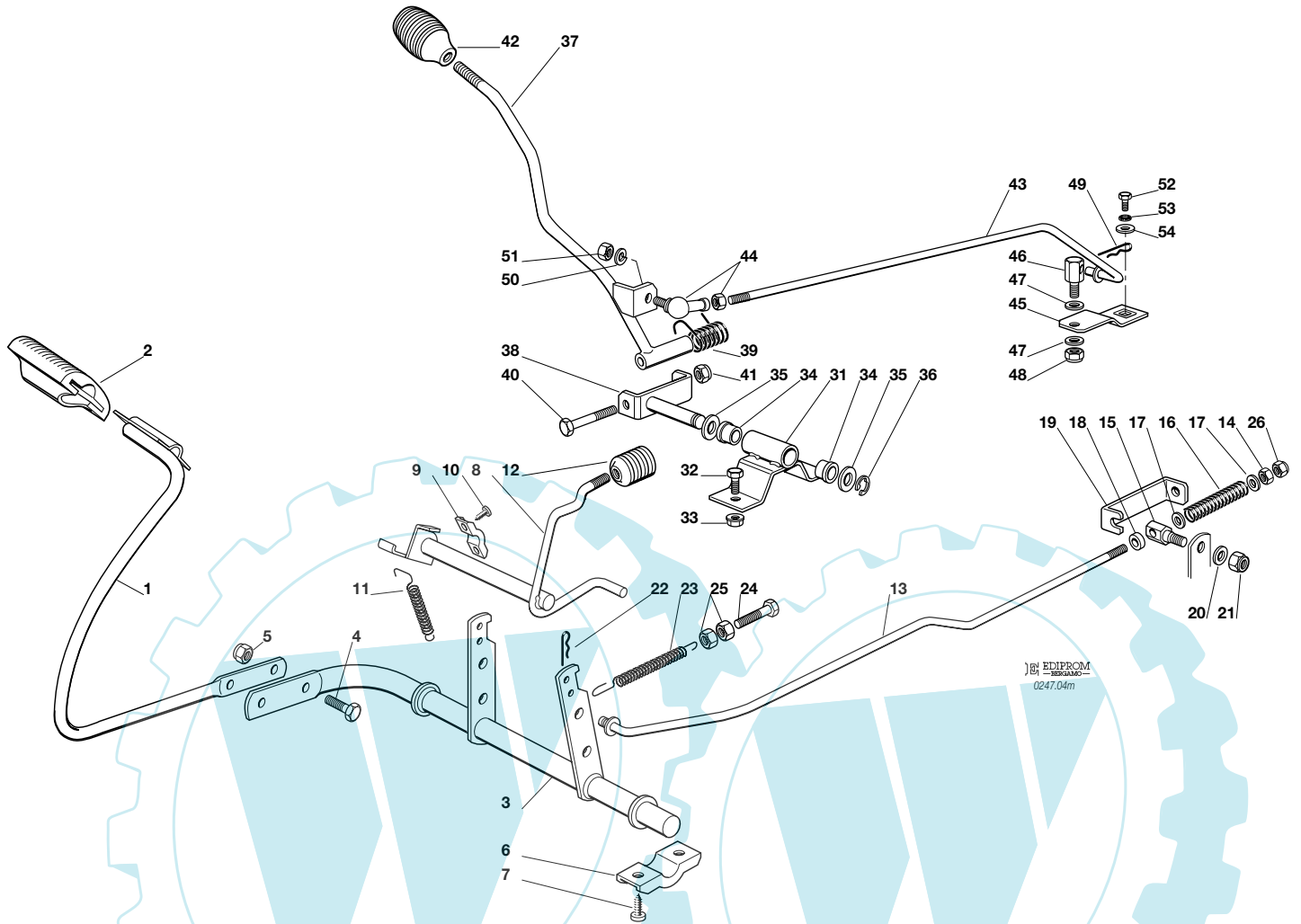

N.	CODE	Q.TY	DESCRIZIONE	DESCRIPTION	DESCRIPTION	BESCHREIBUNG
1	84503001/0	1	PEDALE	PEDAL	PEDAL	PEDAL
2	25110269/0	1	COPRISTAFFA	CLAMP COVER	COUVRE ETRIER	BRIDEDECKEL
3	84001015/1	1	ASSE FRENO	AXLE	ACHSE	ACHSE
4	12793301/0	2	VITE	SCREW	VIS	SCHRAUBE
5	12155000/0	2	DADO	NUT	ECROU	MUTTER
6	27546015/1	2	PIASTRINA	PLATE	PLAQUE	PLATTE
7	12731350/0	4	VITE	SCREW	VIS	SCHRAUBE
8	84001011/2	1	ASSE FRENO STAZIONAM	AXLE	ACHSE	ACHSE
9	25547049/0	2	PIASTRINA	PLATE	PLAQUE	PLATTE
10	12731601/0	4	VITE	SCREW	VIS	SCHRAUBE
11	27430552/0	1	MOLLA	SPRING	RESSORT	FEDER
12	27395050/1	1	MANOPOLA	KNOB	POIGNEE	KNOPF
13	27034059/0	1	ASTA	ROD	BARRE	STANGE
14	12293200/0	1	DADO	NUT	ECROU	MUTTER
15	27510103/0	1	PERNO	PIN	PIVOT	BOLZEN
16	25430236/0	1	MOLLA	SPRING	RESSORT	FEDER
17	12521350/0	2	ROSETTA	WASHER	RONDELLE	SCHEIBE
18	22171001/0	1	DISTANZIALE	SPACER	ENTRETOISE	ENTFERNUNGSSTÜCK
19	25774275/0	1	STAFFA	CLAMP	ETRIER	BRIDE
20	12523050/0	1	ROSETTA	WASHER	RONDELLE	SCHEIBE
21	12154510/0	1	DADO	NUT	ECROU	MUTTER
22	24487997/0	1	COPPIGLIA	COTTER PIN	GOUILLE	SPLIT
23	25430210/0	1	MOLLA	SPRING	RESSORT	FEDER
24	22943005/0	1	VITE	SCREW	VIS	SCHRAUBE
25	12293200/0	2	DADO	NUT	ECROU	MUTTER
26	12155000/0	1	DADO	NUT	ECROU	MUTTER
31	84773551/0	1	STAFFA	CLAMP	ETRIER	BRIDE
32	12793102/0	1	VITE	SCREW	VIS	SCHRAUBE
33	12293201/0	1	DADO	NUT	ECROU	MUTTER



N.	CODE	Q.TY	DESCRIZIONE	DESCRIPTION	DESCRIPTION	BESCHREIBUNG
34	27047002/0	2	BUSSOLA	BUSHING	DOUILLE	LAGER
35	12521370/0	2	RONDELLA	WASHER	RONDELLE	SCHEIBE
36	12608600/0	1	SEEGER	SEEGER	SEEGER	SEEGER
37	84317051/2	1	LEVA	GEARSHIFT	LEVIER	HEBEL
38	84773553/0	1	STAFFA	CLAMP	ETRIER	BRIDE
39	25430226/0	1	MOLLA	SPRING	RESSORT	FEDER
40	12692050/0	1	VITE	SCREW	VIS	SCHRAUBE
41	12155000/0	1	DADO	NUT	ECROU	MUTTER
42	82394508/0	1	MANOPOLA	KNOB	POIGNEE	WECHSEL
43	27034052/0	1	ASTA	ROD	BARRE	STANGE
44	22746601/0	1	SNODO	JOINT	JOINT	GELENK
45	27315077/0	1	LEVA	GEARSHIFT	LEVIER	HEBEL
46	25510040/1	1	PERNO	PIN	PIVOT	BOLZEN
47	25670011/0	2	RONDELLA	WASHER	RONDELLE	SCHEIBE
48	12155000/0	1	DADO	NUT	ECROU	MUTTER
49	24487997/0	1	COPPIGLIA	COTTER PIN	GOUPILLE	SPLIT
50	12583500/0	1	GROWER	GROWER	GROWER	GROWER
51	12293200/0	1	DADO	NUT	ECROU	MUTTER
52	12735520/0	1	VITE	SCREW	VIS	SCHRAUBE
53	12540040/0	1	RONDELLA	WASHER	RONDELLE	SCHEIBE
54	22680009/0	1	RONDELLA	WASHER	RONDELLE	SCHEIBE

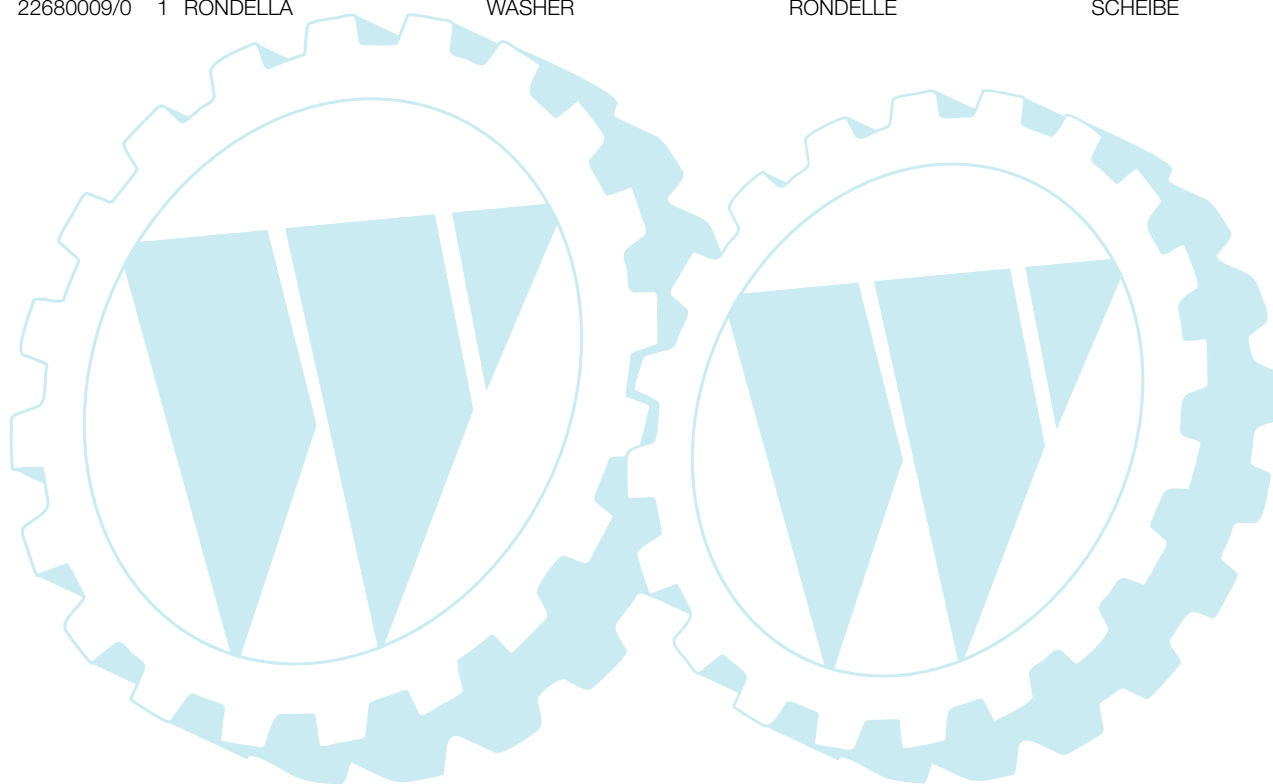

F72

F72 hydro

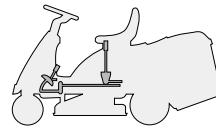

COMANDO TRASMISSIONE E FRENO
DRIVE AND BRAKE CONTROLS
COMMANDE TRANSMISSION ET FREIN
GETRIEBE UND BREMSE ANTRIEB

2003

004Y.0

1 / 2

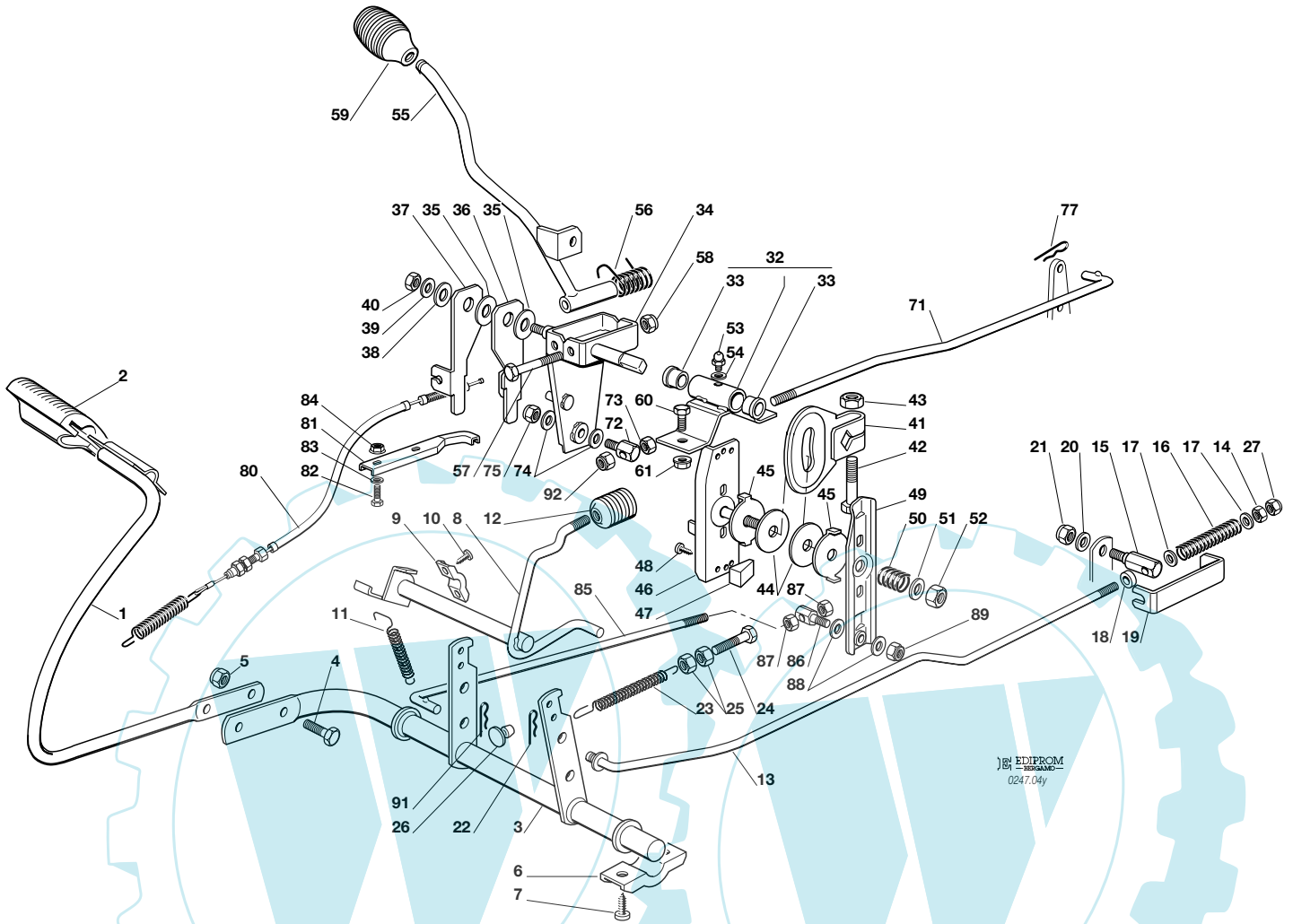

EDIPROM
0247.04y

N.	CODE	Q.TY	DESCRIZIONE	DESCRIPTION	DESCRIPTION	BESCHREIBUNG
1	84503001/0	1	PEDALE	PEDAL	PEDAL	PEDAL
2	25110267/0	1	COPRISTAFFA	CLAMP COVER	COUVRE ETRIER	BRIDEDECKEL
3	84001015/1	1	ASSE FRENO	AXLE	AXLE	ACHSE
4	12793301/0	2	VITE	SCREW	VIS	SCHRAUBE
5	12155000/0	2	DADO	NUT	ECROU	MUTTER
6	27546015/1	2	PIASTRINA	PLATE	PLAQUE	PLATTE
7	12731350/0	4	VITE	SCREW	VIS	SCHRAUBE
8	84001011/2	1	ASSE FRENO STAZIONAM.	AXLE	AXLE	ACHSE
9	25547049/0	2	PIASTRINA	PLATE	PLAQUE	PLATTE
10	12731601/0	4	VITE	SCREW	VIS	SCHRAUBE
11	27430552/0	1	MOLLA	SPRING	RESSORT	FEDER
12	27395050/1	1	MANOPOLA	KNOB	POIGNEE	KNOPF
13	27034060/0	1	ASTA	ROD	BARRE	STANGE
14	12293200/0	1	DADO	NUT	ECROU	MUTTER
15	27510103/0	1	PERNO	PIN	PIVOT	BOLZEN
16	25430236/0	1	MOLLA	SPRING	RESSORT	FEDER
17	12521350/0	2	ROSETTA	WASHER	RONDELLE	SCHEIBE
18	22171001/0	1	DISTANZIALE	SPACER	ENTRETOISE	ENTFERNUNGSSTÜCK
19	25774275/0	1	STAFFA	CLAMP	ETRIER	BRIDE
20	12523050/0	1	ROSETTA	WASHER	RONDELLE	SCHEIBE
21	12154510/0	1	DADO	NUT	ECROU	MUTTER
22	24487997/0	1	COPPIGLIA	COTTER PIN	GOUPILLE	SPLIT
23	25430210/0	1	MOLLA	SPRING	RESSORT	FEDER
24	22943005/0	1	VITE	SCREW	VIS	SCHRAUBE
25	12293200/0	2	DADO	NUT	ECROU	MUTTER
26	27275000/0	1	GOMMINO	GROMMET	CAOUTCHOUC	GUMMI
27	12155000/0	1	DADO	NUT	ECROU	MUTTER
32	84773568/0	1	STAFFA CON BUSSOLE	BRACKET WITH BUSSH	INGSETRIER AVEC DOUILLES	BRIDE MIT LAGERN
33	27045080/0	2	BUSSOLA	BUSHING	DOUILLE	LAGER

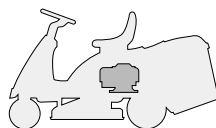

N.	CODE	Q.TY	DESCRIZIONE	DESCRIPTION	DESCRIPTION	BESCHREIBUNG
34	84773561/0	1	LEVA	LEVER	LEVIER	HEBEL
35	22672151/0	2	RONDELLA	WASHER	RONDELLE	SCHEIBE
36	27772101/0	1	STAFFA	CLAMP	ETRIER	BRIDE
37	27772103/0	1	STAFFA	CLAMP	ETRIER	BRIDE
38	22672152/0	1	RONDELLA	WASHER	RONDELLE	SCHEIBE
39	12523060/0	1	RONDELLA	WASHER	RONDELLE	SCHEIBE
40	12155010/0	1	DADO	NUT	ECROU	MUTTER
41	27734055/0	1	SETTORE	SECTOR	SECTEUR	SEKTOR
42	12794900/0	1	VITE	SCREW	VIS	SCHRAUBE
43	12155020/0	1	DADO	NUT	ECROU	MUTTER
44	27158000/0	2	DISCO	PLATE	DISQUE	SCHEIBE
45	27670053/0	2	RONDELLA	WASHER	RONDELLE	SCHEIBE
46	84773565/0	1	STAFFA	CLAMP	ETRIER	BRIDE
47	27063020/0	2	CAMMA	CAM	CAME	NOCKEN
48	12735110/0	2	VITE	SCREW	VIS	SCHRAUBE
49	84773563/0	1	LEVA	LEVER	LEVIER	HEBEL
50	27430560/0	1	MOLLA	SPRING	RESSORT	FEDER
51	25670008/1	1	RONDELLA	WASHER	RONDELLE	SCHEIBE
52	12155020/0	1	DADO	NUT	ECROU	MUTTER
53	12379511/0	1	INGRASSATORE	GREASE DISPENSER	GRAISSEUR	FETTBUCHSE
54	12521330/0	1	RONDELLA	WASHER	RONDELLE	SCHEIBE
55	84317051/2	1	LEVA	GEARSHIFT	LEVIER	HEBEL
56	25430226/0	1	MOLLA	SPRING	RESSORT	FEDER
57	12692050/0	1	VITE	SCREW	VIS	SCHRAUBE
58	12155000/0	1	DADO	NUT	ECROU	MUTTER
59	82394508/0	1	MANOPOLA	KNOB	POIGNEE	WECHSEL
60	12793301/0	1	VITE	SCREW	VIS	SCHRAUBE
61	12293201/0	1	DADO	NUT	ECROU	MUTTER
71	27034062/0	1	ASTA	ROD	BARRE	STANGE
72	25510040/1	1	PERNO	PIN	PIVOT	BOLZEN
73	12293200/0	1	DADO	NUT	ECROU	MUTTER
74	25670011/0	2	RONDELLA	WASHER	RONDELLE	SCHEIBE
75	12155010/0	1	DADO	NUT	ECROU	MUTTER
77	24487997/0	1	COPPIGLIA	COTTER PIN	GOUPILLE	SPLIT
80	84207101/1	1	FILO	WIRE	FIL	KABEL
81	27772105/0	1	STAFFA	CLAMP	ETRIER	BRIDE
82	12791400/0	2	VITE	SCREW	VIS	SCHRAUBE
83	12521330/0	2	RONDELLA	WASHER	RONDELLE	SCHEIBE
84	12292102/0	2	DADO	NUT	ECROU	MUTTER
85	27034058/0	1	ASTA	ROD	BARRE	STANGE
86	25510040/1	1	PERNO	PIN	PIVOT	BOLZEN
87	12293200/0	2	DADO	NUT	ECROU	MUTTER
88	25670011/0	2	RONDELLA	WASHER	RONDELLE	SCHEIBE
89	12155010/0	1	DADO	NUT	ECROU	MUTTER
91	24487997/0	1	COPPIGLIA	COTTER PIN	GOUPILLE	SPLIT
92	12155000/0	1	DADO	NUT	ECROU	MUTTER

F72**F72 hydro**
MOTORE
ENGINE
MOTEUR
MOTOR

10-10,5-11-11,5-12-12,5 HP B&S

2003

005.0

1 / 1

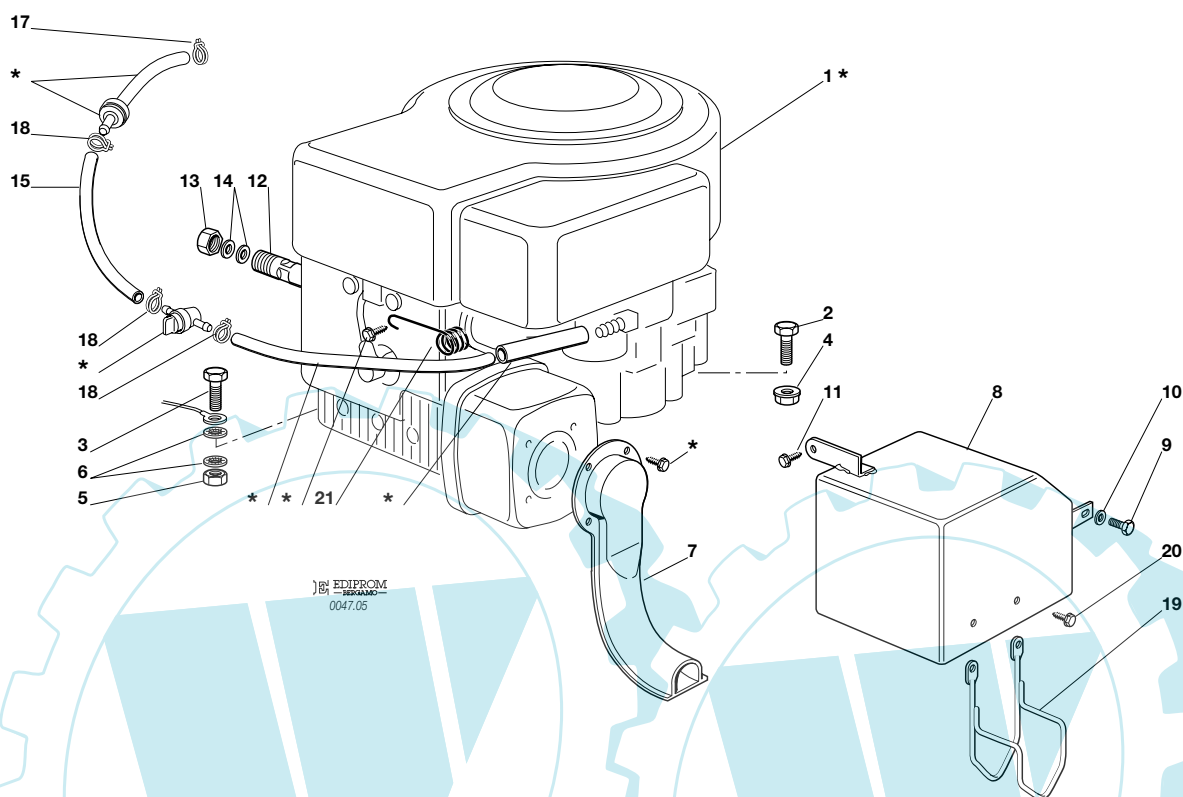

N.	CODE	Q.TY	DESCRIZIONE	DESCRIPTION	DESCRIPTION	BESCHREIBUNG
1*	-	1	MOTORE	ENGINE	MOTEUR	MOTOR
2	12793701/0	3	VITE	SCREW	VIS	SCHRAUBE
3	12691100/0	1	VITE	SCREW	VIS	SCHRAUBE
4	12293201/0	3	DADO	NUT	ECROU	MUTTER
5	12293200/0	1	DADO	NUT	ECROU	MUTTER
6	12540260/0	2	RONDELLA	WASHER	RONDELLE	SCHEIBE
7	84640550/0	1	RACCORDO SCARICO	EXHAUST CONNECTION	CONNEXION ECHAPPEMENT	AUSPUFFANSCHLUSS
8	82598001/0	1	PROTEZIONE SILENZIATORE	MUFFLER PROTECTION	PROTECTION SILENCIEUX	AUSPUFFSCHUTZ
9	12735510/0	1	VITE	SCREW	VIS	SCHRAUBE
10	12540260/0	1	RONDELLA	WASHER	RONDELLE	SCHEIBE
11	12735104/0	1	VITE	SCREW	VIS	SCHRAUBE
12	27598060/0	1	PROLUNGA SCARICO OLIO	OIL DISCHARGE EXTENSION	EXTENSION RALLONGE DE DECH. HUILE	ÖL ENTLEERUNGSVERLÄN- GERUNG
13	18737849/0	1	TAPPO PER PROLUNGA	OIL CAP	BOUCHON HUILE	OELVERSCHLUSS
14	18401001/0	2	GUARNIZIONE	OIL SEAL	GARNITURE	DICHTUNG
15	25869004/0	1	TUBO FILTRO	TUBE	TUBE	ROHR
17	18375053/0	1	FASCETTA	FAIR LED	FIXATION DE CABLE	KABELBEFESTIGUNG
18	18375051/1	3	FASCETTA	FAIR LED	FIXATION DE CABLE	KABELBEFESTIGUNG
19	27600059/1	1	PROTEZIONE SCARICO	EXHAUST PROTECTION	PROTECTION ECHAPPEMENT	AUSPUFFSCHUTZ
20	12735110/0	2	VITE	SCREW	VIS	SCHRAUBE
21	27430562/0	1	MOLLA	SPRING	RESSORT	FEDER

PER LA SOSTITUZIONE DELLE PARTI CONTRASSEGNAE CON «*» RIVOLGERSI AL SERVIZIO ASSISTENZA DEL COSTRUTTORE DEL MOTORE.
 TO REPLACE THE PARTS MARKED «*» SEEK ASSISTANCE FROM THE ENGINE MANUFACTURER'S AFTER SALES SERVICE.
 POUR LE REMPLACEMENT DES PIÈCES MARQUÉES AVEC «*» S'ADRESSER AU SERVICE APRÈS VENTES DU CONSTRUCTEUR DU MOTOREUR.
 ZUM AUSTAUSCH DER MIT «*» GEKENNZEICHNETEN TEILE, WENDEN SIE SICH AN DEN KUNDENDIENST DES HERSTELLERS DES MOTOR.

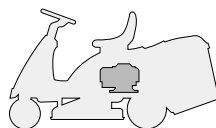
F72**F72 hydro**

MOTORE
ENGINE
MOTEUR
MOTOR
10 HP TECUMSEH

2003

005a.0

1 / 1

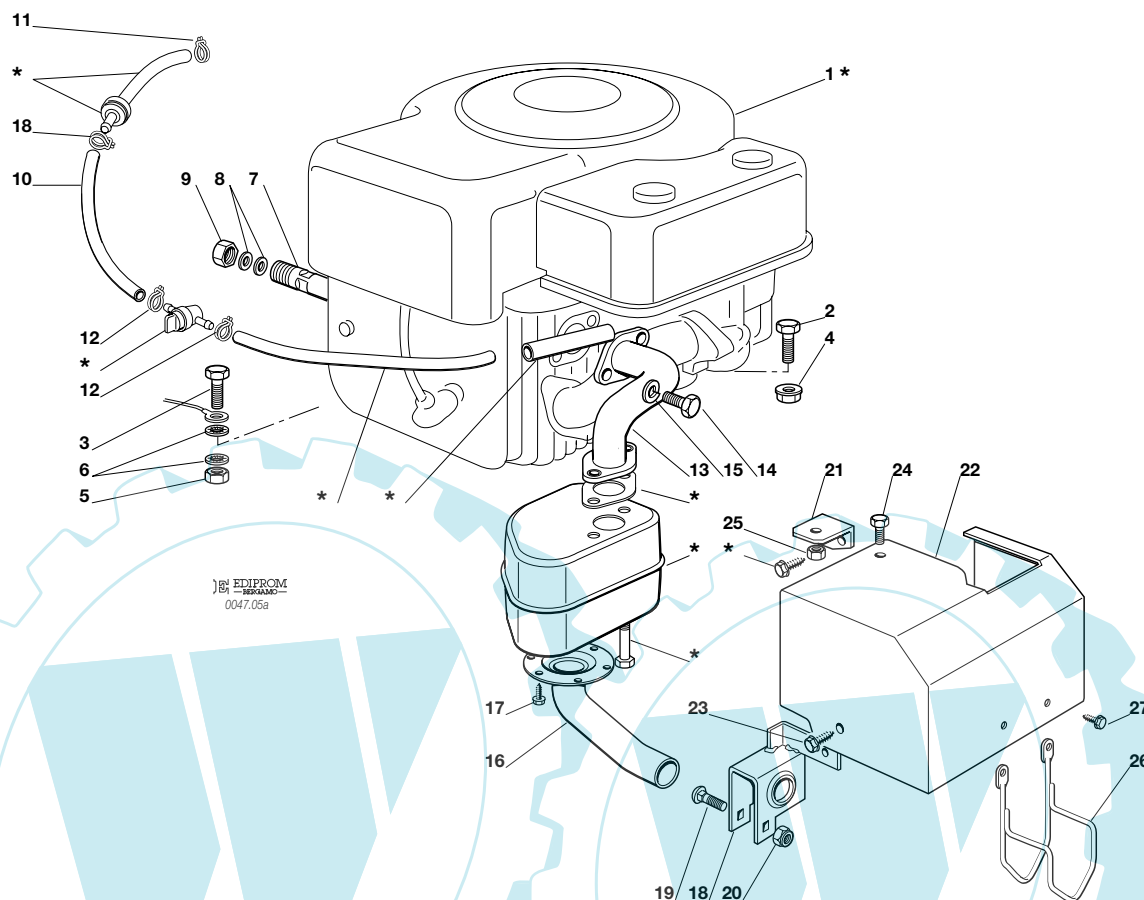

N.	CODE	Q.TY	DESCRIZIONE	DESCRIPTION	DESCRIPTION	BESCHREIBUNG
1*	-	1	MOTORE	ENGINE	MOTEUR	MOTOR
2	12793701/0	3	VITE	SCREW	VIS	SCHRAUBE
3	12691100/0	1	VITE	SCREW	VIS	SCHRAUBE
4	12293201/0	3	DADO	NUT	ECROU	MUTTER
5	12293200/0	1	DADO	NUT	ECROU	MUTTER
6	12540260/0	2	RONDELLA	WASHER	RONDELLE	SCHEIBE
7	27598060/0	1	PROLUNGA SCARICO OLIO	OIL DISCHARGE EXTENSION	EXTENSION RALLONGE DE DECH. HUILE	ÖL ENTLEERUNGSVERLÄNGERUNG
8	18737849/0	1	TAPPO PER PROLUNGA	OIL CAP	BOUCHON HUILE	OELVERSCHLUSS
9	18401001/0	2	GUARNIZIONE	OIL SEAL	GARNITURE	DICHTUNG
10	25869027/0	1	TUBO FILTRO	TUBE	TUBE	ROHR
11	18375053/0	1	FASCETTA	FAIR LED	FIXATION DE CABLE	KABELBEFESTIGUNG
12	18375051/1	3	FASCETTA	FAIR LED	FIXATION DE CABLE	KABELBEFESTIGUNG
13	18738218/0	1	TUBI RACCORDO SCARICO	EXHAUST CONNECTING TUBE	TUBE DE CONNEXION POUR ECHAPPEMENT	VERBINDUNGSROHR FÜR ABGASUNG
14	12737450/0	2	VITE	SCREW	VIS	SCHRAUBE
15	12583500/0	2	GROWER	GROWER	GROWER	GROWER
16	18738216/0	1	TUBI RACCORDO SCARICO	EXHAUST CONNECTING TUBE	TUBE DE CONNEXION POUR ECHAPPEMENT	VERBINDUNGSROHR FÜR ABGASUNG
17	12735106/0	4	VITE	SCREW	VIS	SCHRAUBE
18	84773557/0	1	STAFFA	BRACKET	ETRIER	BRIDE
19	12815240/0	1	VITE	SCREW	VIS	SCHRAUBE
20	12154510/0	1	DADO	NUT	ECROU	MUTTER
21	27546009/0	1	PIASTRINA	PLATE	PLAQUETTE	PLATTE
22	84598061/0	1	PROTEZIONE SILENZIATORE	MUFFLER PROTECTION	PROTECTION SILENCIEUX	AUSPUFFSCHUTZ
23	12731601/0	1	VITE	SCREW	VIS	SCHRAUBE
24	12790780/0	1	VITE	SCREW	VIS	SCHRAUBE
25	12292102/0	1	DADO	NUT	ECROU	MUTTER
26	27600059/1	1	PROTEZIONE SCARICO	EXHAUST PROTECTION	PROTECTION ECHAPPEMENT	AUSPUFFSCHUTZ
27	12735110/0	2	VITE	SCREW	VIS	SCHRAUBE

PER LA SOSTITUZIONE DELLE PARTI CONTRASSEGNAE CON «*» RIVOLGERSI AL SERVIZIO ASSISTENZA DEL COSTRUTTORE DEL MOTORE.
 TO REPLACE THE PARTS MARKED «*» SEEK ASSISTANCE FROM THE ENGINE MANUFACTURER'S AFTER SALES SERVICE.
 POUR LE REMPLACEMENT DES PIÈCES MARQUÉES AVEC «*» S'ADRESSER AU SERVICE APRÈS VENTES DU CONSTRUCTEUR DU MOTEUR.
 ZUM AUSTAUSCH DER MIT «*» GEKENNZEICHNETEN TEILE, WENDEN SIE SICH AN DEN KUNDENDIENST DES HERSTELLERS DES MOTOR.

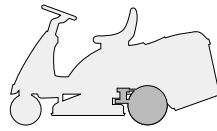
F72*F72 hydro*
TRASMISSIONE
TRANSMISSION
TRANSMISSION
GETRIEBE

2003

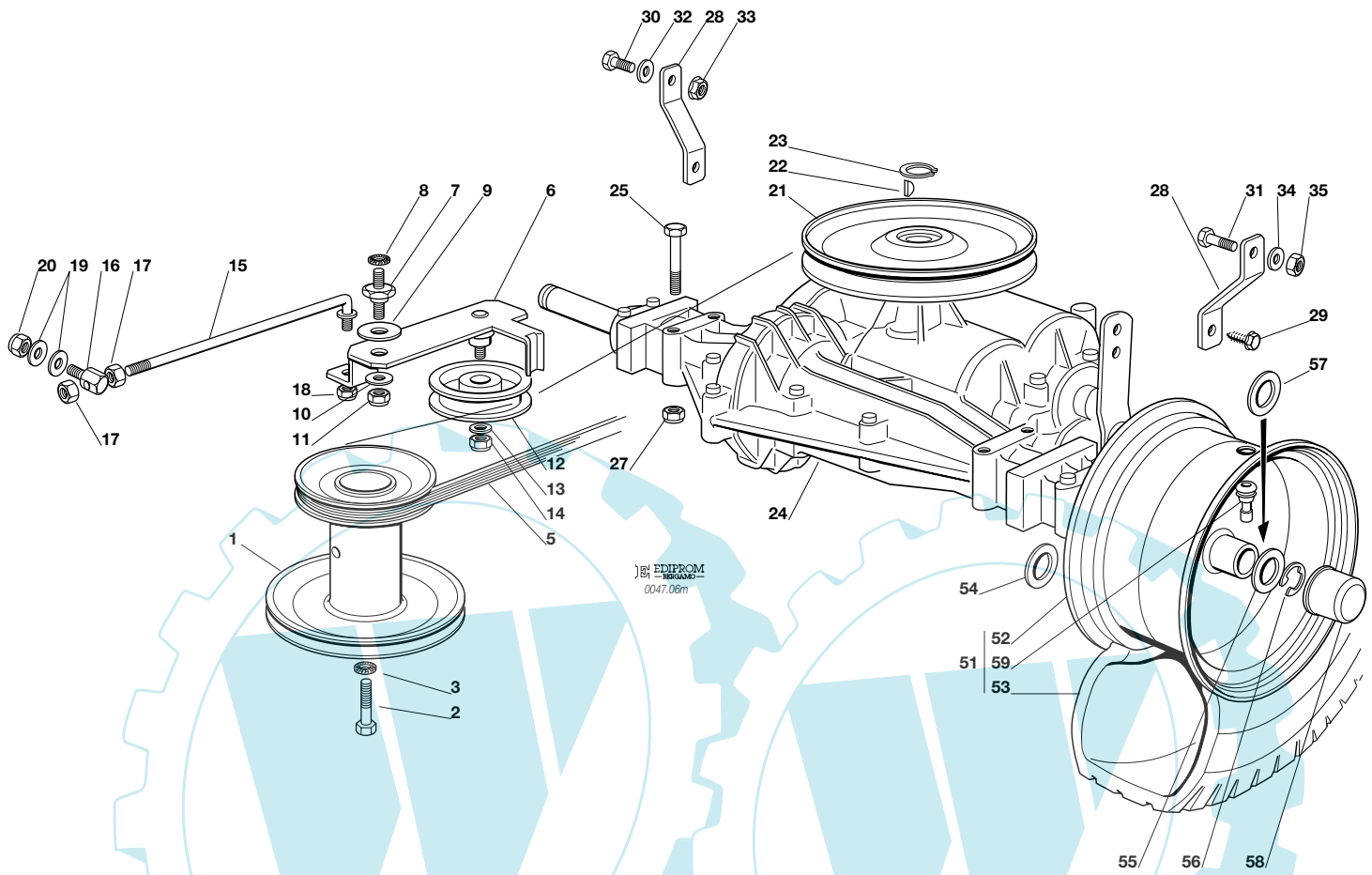

006M.0

1 / 2



N.	CODE	Q.TY	DESCRIZIONE	DESCRIPTION	DESCRIPTION	BESCHREIBUNG
1	27604003/1	1	PULEGGIA	PULLEY	POULIE	RIEMENSCHLEIBE
2	12737310/0	1	VITE	SCREW	VIS	SCHRAUBE
3	12543000/0	1	ROSETTA	WASHER	RONDELLE	SCHEIBE
5	35061400/0	1	CINGHIA	BELT	COURROIE	RIEMEN
6	84317055/0	1	LEVA	LEVER	LEVIER	HEBEL
7	27510096/0	1	PERNO	PIN	PIVOT	BOLZEN
8	12540260/0	1	RONDELLA	WASHER	RONDELLE	SCHEIBE
9	22672151/0	1	RONDELLA	WASHER	RONDELLE	SCHEIBE
10	25670011/0	1	RONDELLA	WASHER	RONDELLE	SCHEIBE
11	12155010/0	1	DADO	NUT	ECROU	MUTTER
12	25601554/0	1	PULEGGIA	PULLEY	POULIE	RIEMENSCHLEIBE
13	12523060/0	1	RONDELLA	WASHER	RONDELLE	SCHEIBE
14	12155000/0	1	DADO	NUT	ECROU	MUTTER
15	27034054/0	1	TIRANTE	TIE ROD	TIRANT	SPANNSTANGE
16	25510040/1	1	PERNO	PIN	PIVOT	BOLZEN
17	12293200/0	2	DADO	NUT	ECROU	MUTTER
18	12155000/0	1	DADO	NUT	ECROU	MUTTER
19	25670011/0	2	RONDELLA	WASHER	RONDELLE	SCHEIBE
20	12155000/0	1	DADO	NUT	ECROU	MUTTER
21	82601503/0	1	PULEGGIA	PULLEY	POULIE	RIEMENSCHLEIBE
22	12139430/0	1	LINGUETTA	KEY	CLAVETTE	KEIL
23	12608950/0	1	ANELLO ELASTICO	SNAP RING	ANNEAU RESSORT	SPRENGRING
24*	18400915/2	1	ASSE POSTERIORE	REAR AXLE	AXE ARRIERE	HINTERACHSE
25	12691800/0	4	VITE	SCREW	VIS	SCHRAUBE
27	12154210/0	4	DADO	NUT	ECROU	MUTTER
28	27772067/0	2	STAFFA	CLAMP	ETRIER	BRIDE
29	12735150/0	2	VITE	SCREW	VIS	SCHRAUBE
30	12793102/0	1	VITE	SCREW	VIS	SCHRAUBE
31	12793301/0	1	VITE	SCREW	VIS	SCHRAUBE
32	12523060/0	1	RONDELLA	WASHER	RONDELLE	SCHEIBE
33	12293201/0	1	DADO	NUT	ECROU	MUTTER



N.	CODE	Q.TY	DESCRIZIONE	DESCRIPTION	DESCRIPTION	BESCHREIBUNG
34	12521350/0	1	RONDELLA	WASHER	RONDELLE	SCHEIBE
35	12155000/0	1	DADO	NUT	ECROU	MUTTER
51		2	RUOTA POSTERIORE	REAR WHEEL	ROUE ARRIERE	HINTERRAD
	84680050/0		TURF SAVER CARLISLE	TURF SAVER CARLISLE	TURF SAVER CARLISLE	TURF SAVER CARLISLE
	84680053/0		DELI TIRE	DELI TIRE	DELI TIRE	DELI TIRE
52	84044001/0	1	CERCHIO RUOTA	RIMM	BANDAGE ROUE	HINTRERRAD FELGER
53		1	PNEUMATICO	SHOE	PNEU	REIFEN
	27590051/0		TURF SAVER CARLISLE	TURF SAVER CARLISLE	TURF SAVER CARLISLE	TURF SAVER CARLISLE
	27590053/0		DELI TIRE	DELI TIRE	DELI TIRE	DELI TIRE
54	12521410/0	2	RONDELLA	WASHER	RONDELLE	SCHEIBE
55	25670005/1	2	RONDELLA	WASHER	RONDELLE	SCHEIBE
56	12001010/0	2	ANELLO ELASTICO	SNAP RING	ANNEAU RESSORT	SPRENGRING
57	12520010/0	2-4	ROSETTA	WASHER	RONDELLE	SCHEIBE
58	22110230/0	2	COPRIMOZZO	HUB COVER	COUVRE MOYEU	NABEDECKEL
59	25950000/0	2	VALVOLA	VALVE	SOUPAPE	VENTIL

PER LA SOSTITUZIONE IN GARANZIA DELLE PARTI CONTRASSEGNAE CON «*» RIVOLGERSI AL SERVIZIO ASSISTENZA DEL COSTRUTTORE
 TO REPLACE UNDER GUARANTEE THE PARTS MARKED «*» SEEK ASSISTANCE FROM MANUFACTURER'S AFTER SALES SERVICE (TECUMSEH).
 POUR LE REMPLACEMENT, SOUS GARANTIE DES PIÈCES MARQUÉES AVEC «*» S'ADRESSER AU SERVICE APRÈS VENTES DU CONSTRUCTEUR
 ZUM AUSTAUSCH DER MIT «*» GEKENNZEICHNETEN TEILE IM RAHMEN DER GARANTIE, WENDEN SIE SICH AN DEN KUNDENDIENST DES HER-
 STELLERS

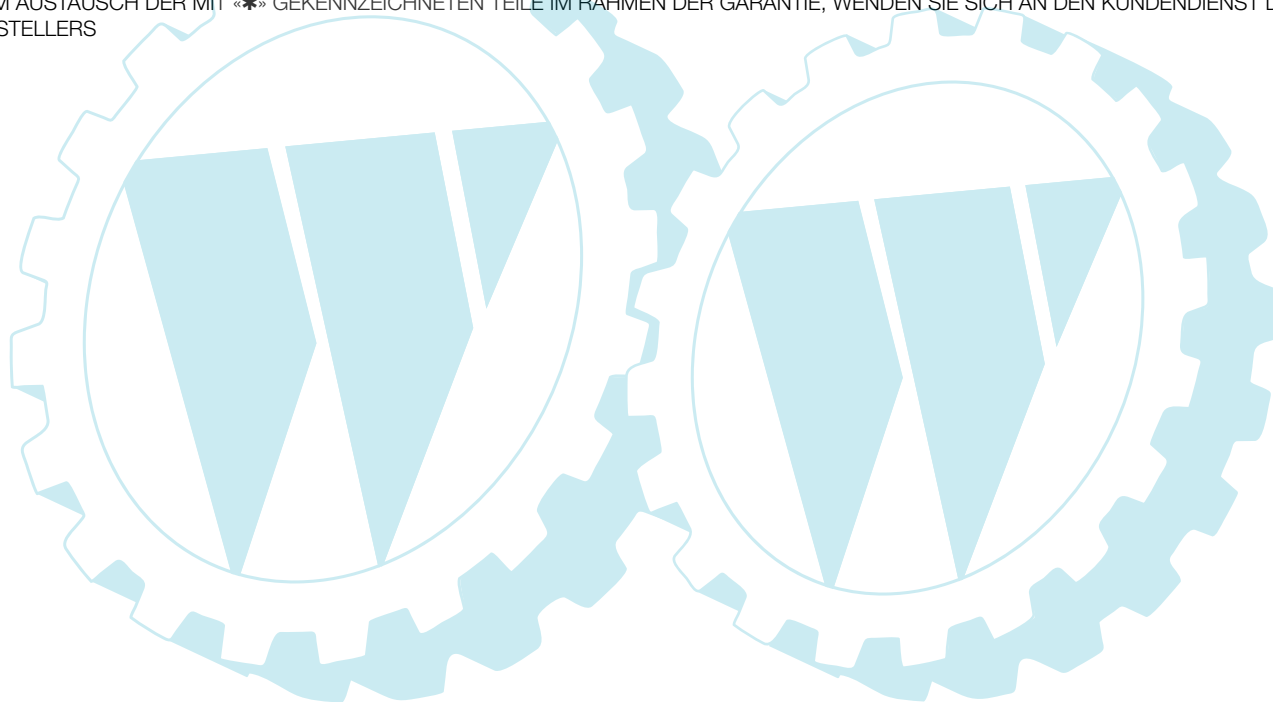

F72

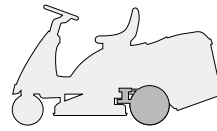
F72 hydro
TRASMISSIONE
TRANSMISSION
TRANSMISSION
GETRIEBE

2003

006Y.0

1 / 2

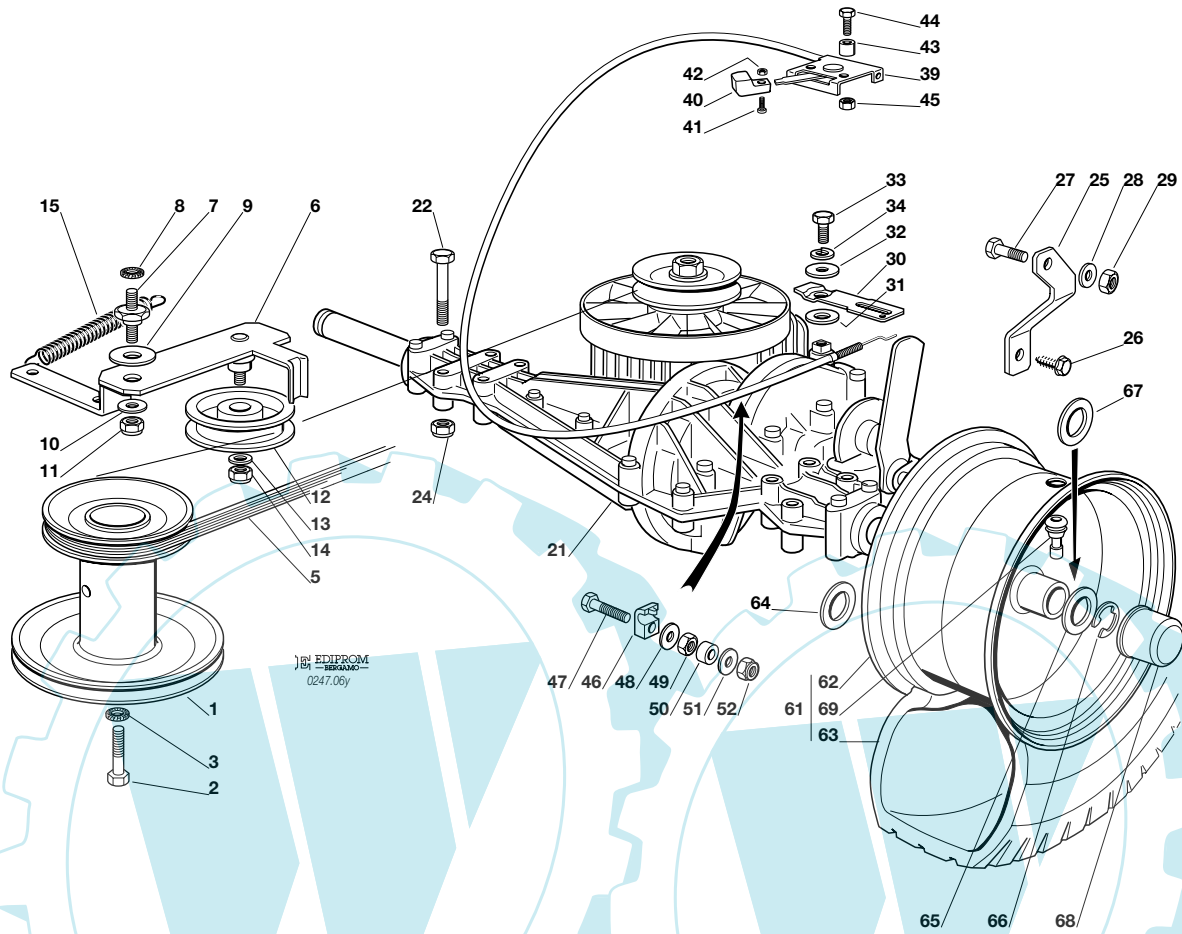

N.	CODE	Q.TY	DESCRIZIONE	DESCRIPTION	DESCRIPTION	BESCHREIBUNG
1	27604003/1	1	PULEGGIA	PULLEY	POULIE	RIEMENSCHLEIBE
2	12737310/0	1	VITE	SCREW	VIS	SCHRAUBE
3	12543000/0	1	ROSETTA	WASHER	RONDELLE	SCHLEIBE
5	35061403/0	1	CINGHIA	BELT	COURROIE	RIEMEN
6	84317067/0	1	LEVA	LEVER	LEVIER	HEBEL
7	27510096/0	1	PERNO	PIN	PIVOT	BOLZEN
8	12540260/0	1	RONDELLA	WASHER	RONDELLE	SCHLEIBE
9	22672151/0	1	RONDELLA	WASHER	RONDELLE	SCHLEIBE
10	25670011/0	1	RONDELLA	WASHER	RONDELLE	SCHLEIBE
11	12155010/0	1	DADO	NUT	ECROU	MUTTER
12	25601554/0	1	PULEGGIA	PULLEY	POULIE	RIEMENSCHLEIBE
13	12523060/0	1	RONDELLA	WASHER	RONDELLE	SCHLEIBE
14	12155000/0	1	DADO	NUT	ECROU	MUTTER
15	22446402/0	1	MOLLA	SPRING	RESSORT	FEDER
21*	18400936/0	1	ASSE POSTERIORE	REAR AXLE	AXE ARRIERE	HINTERACHSE
22	12691800/0	4	VITE	SCREW	VIS	SCHRAUBE
24	12154210/0	4	DADO	NUT	ECROU	MUTTER
25	27772115/0	1	STAFFA	CLAMP	ETRIER	BRIDE
26	12735150/0	1	VITE	SCREW	VIS	SCHRAUBE
27	12793301/0	1	VITE	SCREW	VIS	SCHRAUBE
28	12521350/0	1	RONDELLA	WASHER	RONDELLE	SCHLEIBE
29	12155000/0	1	DADO	NUT	ECROU	MUTTER
30	27315119/0	1	LEVA	LEVER	LEVIER	HEBEL
31	12521370/0	1	RONDELLA	WASHER	RONDELLE	SCHLEIBE
32	12523050/0	1	RONDELLA	WASHER	RONDELLE	SCHLEIBE
33	12735520/0	1	VITE	SCREW	VIS	SCHRAUBE
34	12582100/0	1	GROWER	GROWER	GROWER	GROWER
39	84040350/0	1	COMANDO SBLOCCO	DISENGAGE CONTROL	COMMANDE DEBLOCAGE	ENTSPERREN HEBEL
40	22399801/0	1	MANOPOLINA	HANDLE	POIGNEE	GRIFF



N.	CODE	Q.TY	DESCRIZIONE	DESCRIPTION	DESCRIPTION	BESCHREIBUNG
41	12726388/0	1	VITE	SCREW	VIS	SCHRAUBE
42	12290800/0	1	DADO	NUT	ECROU	MUTTER
43	25160012/0	2	DISTANZIALE	SPACER	ENTRETOISE	ENTFERNUNGSSTÜCK
44	12674550/0	2	VITE	SCREW	VIS	SCHRAUBE
45	12154510/0	2	DADO	NUT	ECROU	MUTTER
46	27546025/0	1	PIASTRINA	PLATE	PLAQUETTE	PLATTE
47	12789100/0	1	VITE	SCREW	VIS	SCHRAUBE
48	12523020/0	1	RONDELLA	WASHER	RONDELLE	SCHEIBE
49	12291000/0	1	DADO	NUT	ECROU	MUTTER
50	25170600/0	1	DISTANZIALE	SPACER	ENTRETOISE	ENTFERNUNGSSTÜCK
51	12523020/0	1	RONDELLA	WASHER	RONDELLE	SCHEIBE
52	12154330/0	1	DADO	NUT	ECROU	MUTTER
61	84680050/0	2	RUOTA POSTERIORE	REAR WHEEL	ROUE ARRIERE	HINTERRAD
	84680053/0		TURF SAVER CARLISLE	TURF SAVER CARLISLE	TURF SAVER CARLISLE	TURF SAVER CARLISLE
	84680053/0		DELI TIRE	DELI TIRE	DELI TIRE	DELI TIRE
62	84044001/0	1	CERCHIO RUOTA	RIMM	BANDAGE ROUE	HINTRERRAD FELGER
63	27590051/0	1	PNEUMATICO	SHOE	PNEU	REIFEN
	27590051/0		TURF SAVER CARLISLE	TURF SAVER CARLISLE	TURF SAVER CARLISLE	TURF SAVER CARLISLE
	27590053/0		DELI TIRE	DELI TIRE	DELI TIRE	DELI TIRE
64	12521410/0	2	RONDELLA	WASHER	RONDELLE	SCHEIBE
65	25670005/1	2	RONDELLA	WASHER	RONDELLE	SCHEIBE
66	12001010/0	2	ANELLO ELASTICO	SNAP RING	ANNEAU RESSORT	SPRENGRING
67	12520010/0	0-4	ROSETTA	WASHER	RONDELLE	SCHEIBE
68	22110230/0	2	COPRIMOZZO	HUB COVER	COUVRE MOYEU	NABEDECKEL
69	25950000/0	2	VALVOLA	VALVE	SOUPAPE	VENTIL

PER LA SOSTITUZIONE IN GARANZIA DELLE PARTI CONTRASSEGNALE CON «*» RIVOLGERSI AL SERVIZIO ASSISTENZA DEL COSTRUTTORE (TECUMSEH).

TO REPLACE UNDER GUARANTEE THE PARTS MARKED «*» SEEK ASSISTANCE FROM MANUFACTURER'S AFTER SALES SERVICE (TECUMSEH).
POUR LE REMPLACEMENT, SOUS GARANTIE DES PIÈCES MARQUÉES AVEC «*» S'ADRESSER AU SERVICE APRÈS VENTES DU CONSTRUCTEUR (TECUMSEH).

ZUM AUSTAUSCH DER MIT «*» GEKENNZEICHNETEN TEILE IM RAHMEN DER GARANTIE, WENDEN SIE SICH AN DEN KUNDENDIENST DES HERSTELLERS (TECUMSEH).

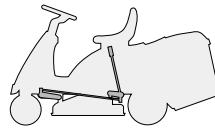
F72**F72 hydro**

SOLLEVAMENTO PIATTO DI TAGLIO
CUTTING PLATE LIFTING
SOULEVEMENT PLATEAU DE COUPE
SCHNEIDWERKZEUG AUFHEBESATZ

2003

007.0

1 / 1

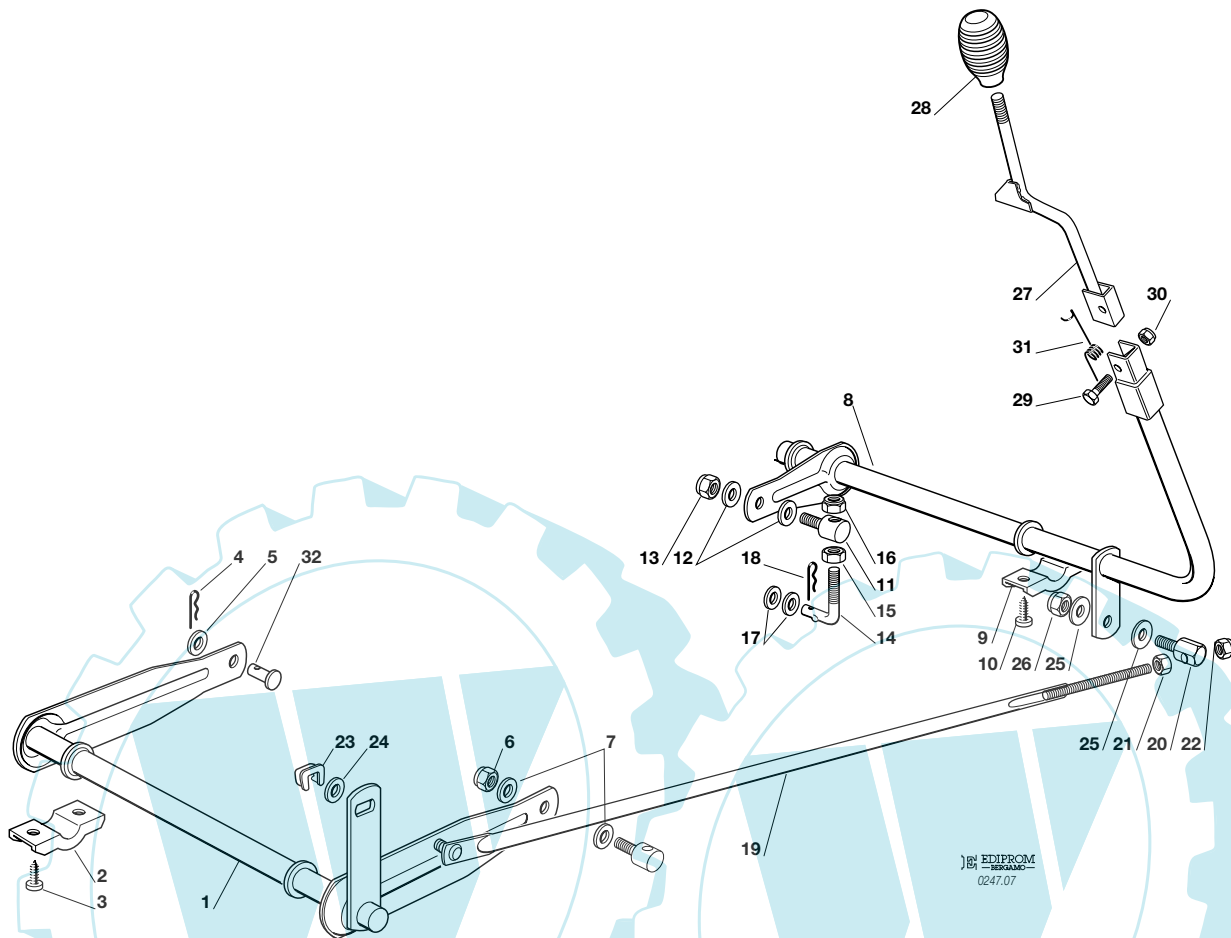

N.	CODE	Q.TY	DESCRIZIONE	DESCRIPTION	DESCRIPTION	BESCHREIBUNG
1	84001025/0	1	ASSE FULCRO PIATTO	AXLE	AXE	ACHSE
2	27546015/1	2	PIASTRINA	PLATE	PLAQUE	PLATTE
3	12731350/0	4	VITE	SCREW	VIS	SCHRAUBE
4	24487997/0	1	COPPIGLIA	COTTER PIN	GOUPILLE	SPLIT
5	25670008/1	1	RONDELLA	WASHER	RONDELLE	SCHEIBE
6	12156602/0	1	DADO	NUT	ECROU	MUTTER
7	25670008/1	2	RONDELLA	WASHER	RONDELLE	SCHEIBE
8	84001005/1	1	ASSE FULCRO PIATTO	AXLE	AXE	ACHSE
9	27546015/1	2	PIASTRINA	PLATE	PLAQUE	PLATTE
10	12731350/0	4	VITE	SCREW	VIS	SCHRAUBE
11	25510007/1	1	PERNO	PIN	PIVOT	BOLZEN
12	25670008/1	2	RONDELLA	WASHER	RONDELLE	SCHEIBE
13	12156602/0	1	DADO	NUT	ECROU	MUTTER
14	25840003/2	1	TIRANTE	TIE ROD	TIRANT	SPANNSTANGE
15	12295200/0	1	DADO	NUT	ECROU	MUTTER
16	12156602/0	1	DADO	NUT	ECROU	MUTTER
17	25670008/1	2	RONDELLA	WASHER	RONDELLE	SCHEIBE
18	24487997/0	1	COPPIGLIA	COTTER PIN	GOUPILLE	SPLIT
19	84002051/0	1	ASTA COLLEGAMENTO	ROD	TIGE	STAB
20	25510040/1	1	PERNO	PIN	PIVOT	BOLZEN
21	12293200/0	1	DADO	NUT	ECROU	MUTTER
22	12155000/0	1	DADO	NUT	ECROU	MUTTER
23	12436050/0	1	PIASTRINA	PLATE	PLAQUE	PLATTE
24	25670011/0	1	RONDELLA	WASHER	RONDELLE	SCHEIBE
25	25670011/0	2	RONDELLA	WASHER	RONDELLE	SCHEIBE
26	12155000/0	1	DADO	NUT	ECROU	MUTTER
27	84317065/1	1	LEVA SOLLEVAMENTO	LEVER	LEVIER	HEBEL
28	25394510/0	1	MANOPOLA	KNOB	POIGNEE	GRIFF
29	12674700/0	1	VITE	SCREW	VIS	SCHRAUBE
30	12154510/0	1	DADO	NUT	ECROU	MUTTER
31	27430555/0	1	MOLLA	SPRING	RESSORT	FEDER
32	27510114/0	1	PERNO	PIN	PIVOT	BOLZEN

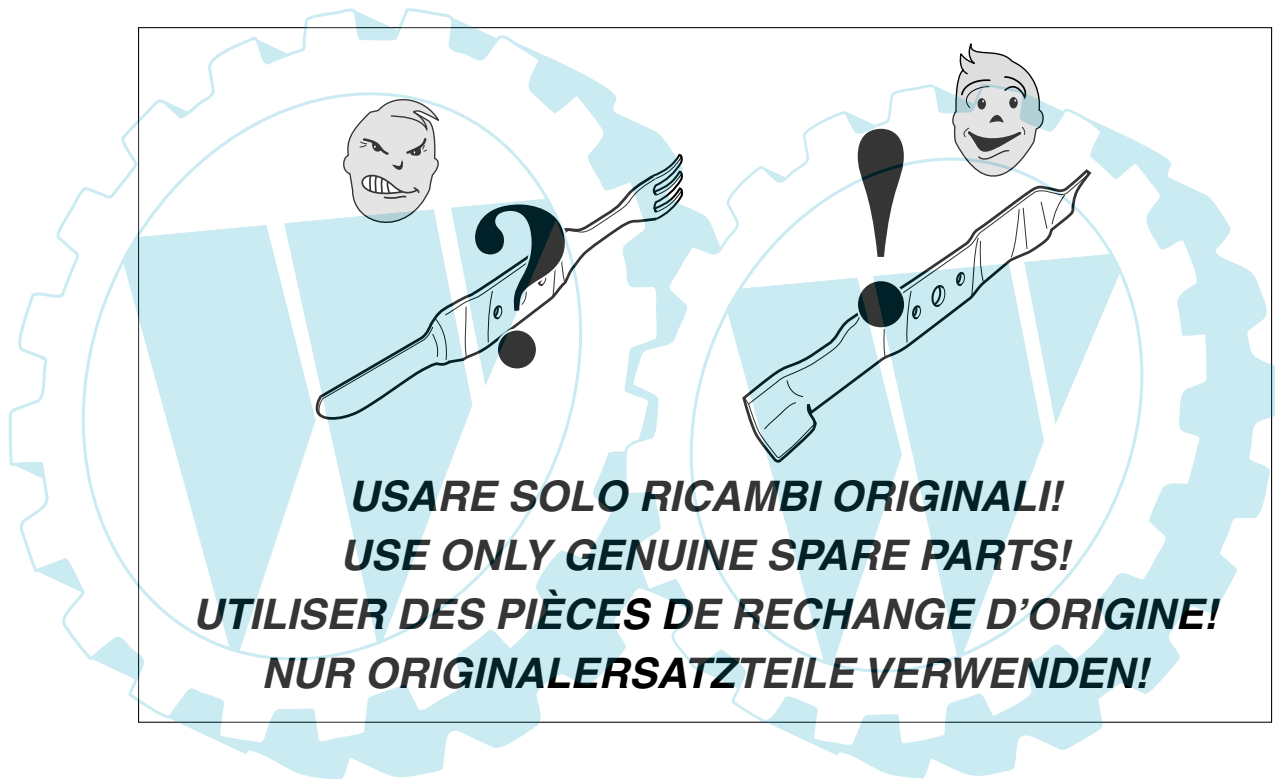

F72

F72 hydro

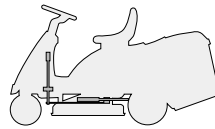

**PIATTO DI TAGLIO (1)
CUTTING PLATE (1)
PLATEAU DE COUPE (1)
SCHNEIDWERKZEUG (1)**

2003

008.0

1 / 2

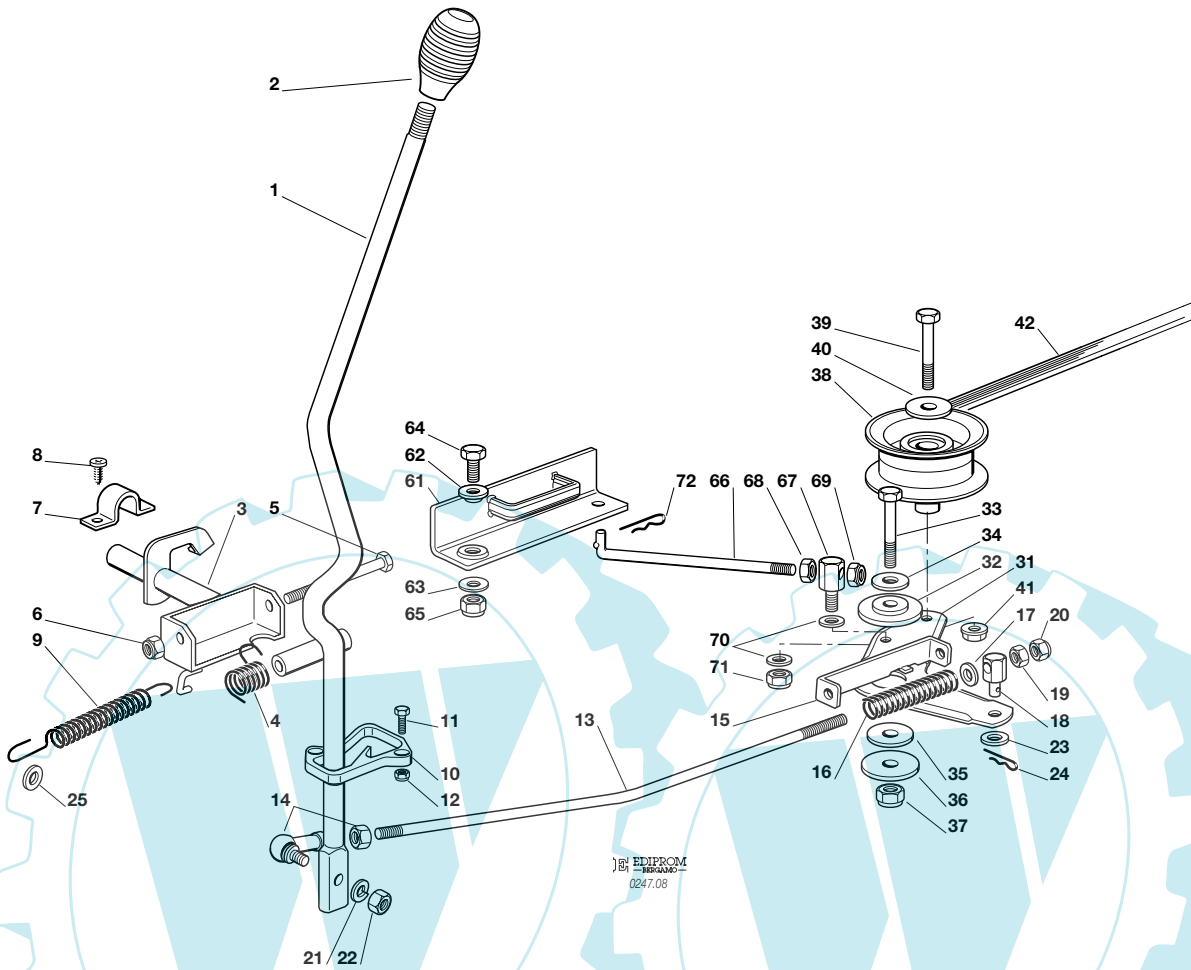

N.	CODE	Q.TY	DESCRIZIONE	DESCRIPTION	DESCRIPTION	BESCHREIBUNG
1	84317069/0	1	LEVA	LEVER	LEVIER	HEBEL
2	25394510/0	1	MANOPOLA	KNOB	POIGNEE	GRIF
3	84001007/0	1	ASSE INNESTO LAMA	AXLE	AXE	ACHSE
4	25430226/0	1	MOLLA	SPRING	RESSORT	FEDER
5	12692050/0	1	VITE	SCREW	VIS	SCHRAUBE
6	12155000/0	1	DADO	NUT	ECROU	MUTTER
7	25547049/0	2	PIASTRINA	PLATE	PLAQUE	PLATTE
8	12731601/0	4	VITE	SCREW	VIS	SCHRAUBE
9	25430571/0	1	MOLLA	SPRING	RESSORT	FEDER
10	27487000/0	1	PATTINO	SHOE	BLOC DE GLISSEMENT	GLEITBLOCK
11	12791200/0	2	VITE	SCREW	VIS	SCHRAUBE
12	12154510/0	2	DADO	NUT	ECROU	MUTTER
13	27034078/0	1	ASTA	ROD	TIGE	STAB
14	22746601/0	1	SNODO	JOINT	JOINT	GELENK
15	27772143/0	1	STAFFA	CLAMP	ETRIER	BRIDE
16	25430576/0	1	MOLLA	SPRING	RESSORT	FEDER
17	12521350/0	1	RONDELLA	WASHER	RONDELLE	SCHEIBE
18	27510113/0	1	PERNO	PIN	PIVOT	BOLZEN
19	12293200/0	1	DADO	NUT	ECROU	MUTTER
20	12155000/0	1	DADO	NUT	ECROU	MUTTER
21	12583500/0	1	GROWER	GROWER	GROWER	GROWER
22	12293200/0	1	DADO	NUT	ECROU	MUTTER
23	25670008/1	1	RONDELLA	WASHER	RONDELLE	SCHEIBE
24	24487997/0	1	COPPIGLIA	COTTER PIN	GOUPILLE	SPLIT
25	25670006/0	1	RONDELLA	WASHER	RONDELLE	SCHEIBE
31	84317083/0	1	LEVA	LEVER	LEVIER	HEBEL
32	27047000/0	1	BUSSOLA	BUSH	DOUILLE	BÜCHSE
33	12691200/0	1	VITE	SCREW	VIS	SCHRAUBE
34	12523060/0	1	RONDELLA	WASHER	RONDELLE	SCHEIBE



 **F72 • F72 hydro**

2003

008.0

2 / 2

N.	CODE	Q.TY	DESCRIZIONE	DESCRIPTION	DESCRIPTION	BESCHREIBUNG
35	22672152/0	1	RONDELLA	WASHER	RONDELLE	SCHEIBE
36	12523070/0	1	RONDELLA	WASHER	RONDELLE	SCHEIBE
37	12155000/0	1	DADO	NUT	ECROU	MUTTER
38	27604008/0	1	PULEGGIA	PULLEY	POULIE	RIEMENSCHLEIBE
39	12691600/0	1	VITE	SCREW	VIS	SCHRAUBE
40	12523060/0	1	ROSETTA	WASHER	RONDELLE	SCHEIBE
41	12293201/0	1	DADO	NUT	ECROU	MUTTER
42	35061423/0	1	CINGHIA	BELT	COURROIE	RIEMEN
61	84220501/0	1	FRENO LAMA	BRAKE	FREIN	BREMSE
62	22041980/0	1	BUSSOLA	BUSH	DOUILLE	BÜCHSE
63	22672152/0	1	RONDELLA	WASHER	RONDELLE	SCHEIBE
64	12793102/0	1	VITE	SCREW	VIS	SCHRAUBE
65	12155010/0	1	DADO	NUT	ECROU	MUTTER
66	27034077/0	1	ASTA	ROD	TIGE	STAB
67	25510040/1	1	PERNO	PIN	PIVOT	BOLZEN
68	12293200/0	1	DADO	NUT	ECROU	MUTTER
69	12155000/0	1	DADO	NUT	ECROU	MUTTER
70	25670011/0	2	RONDELLA	WASHER	RONDELLE	SCHEIBE
71	12155000/0	1	DADO	NUT	ECROU	MUTTER
72	24487997/0	1	COPPIGLIA	COTTER PIN	GOUPILLE	SPLIT

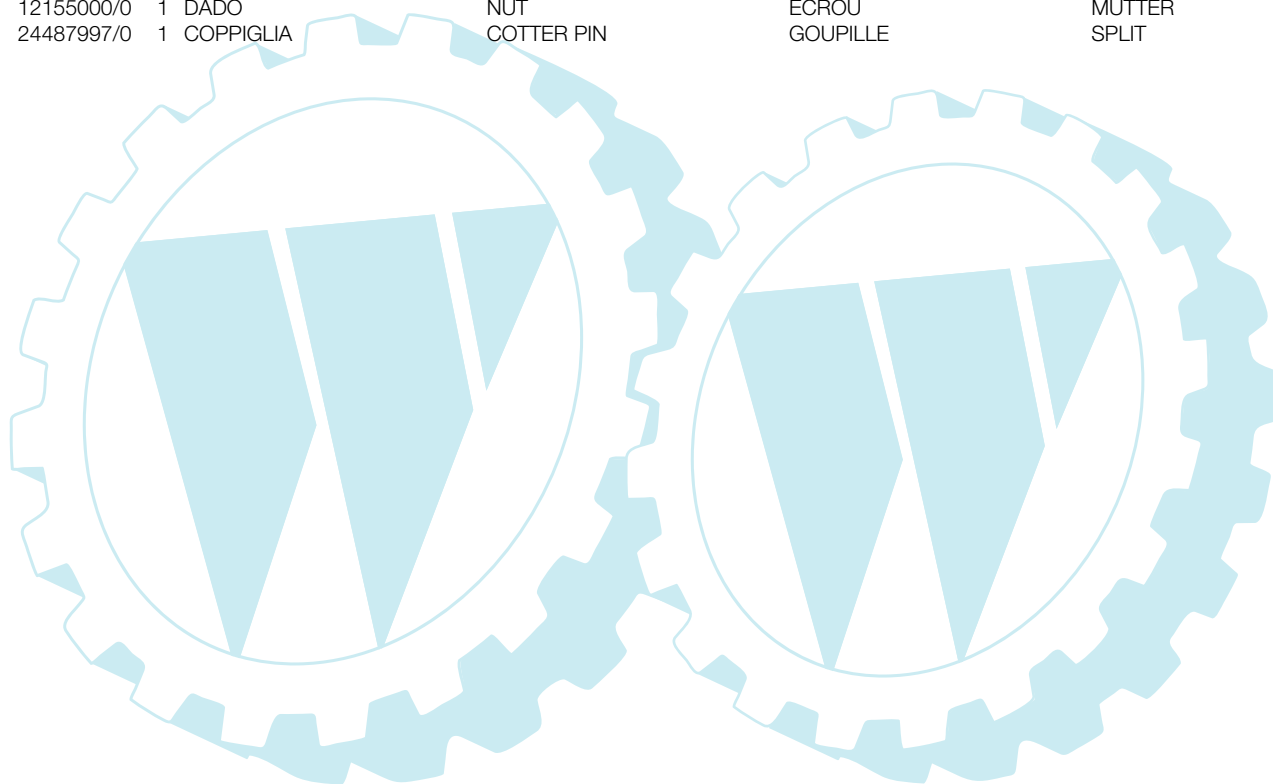

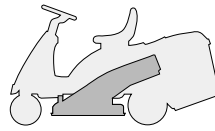
F72**F72 hydro**

PIATTO DI TAGLIO (2)
CUTTING PLATE (2)
PLATEAU DE COUPE (2)
SCHNEIDWERKZEUG (2)

2003

009.0

1 / 2

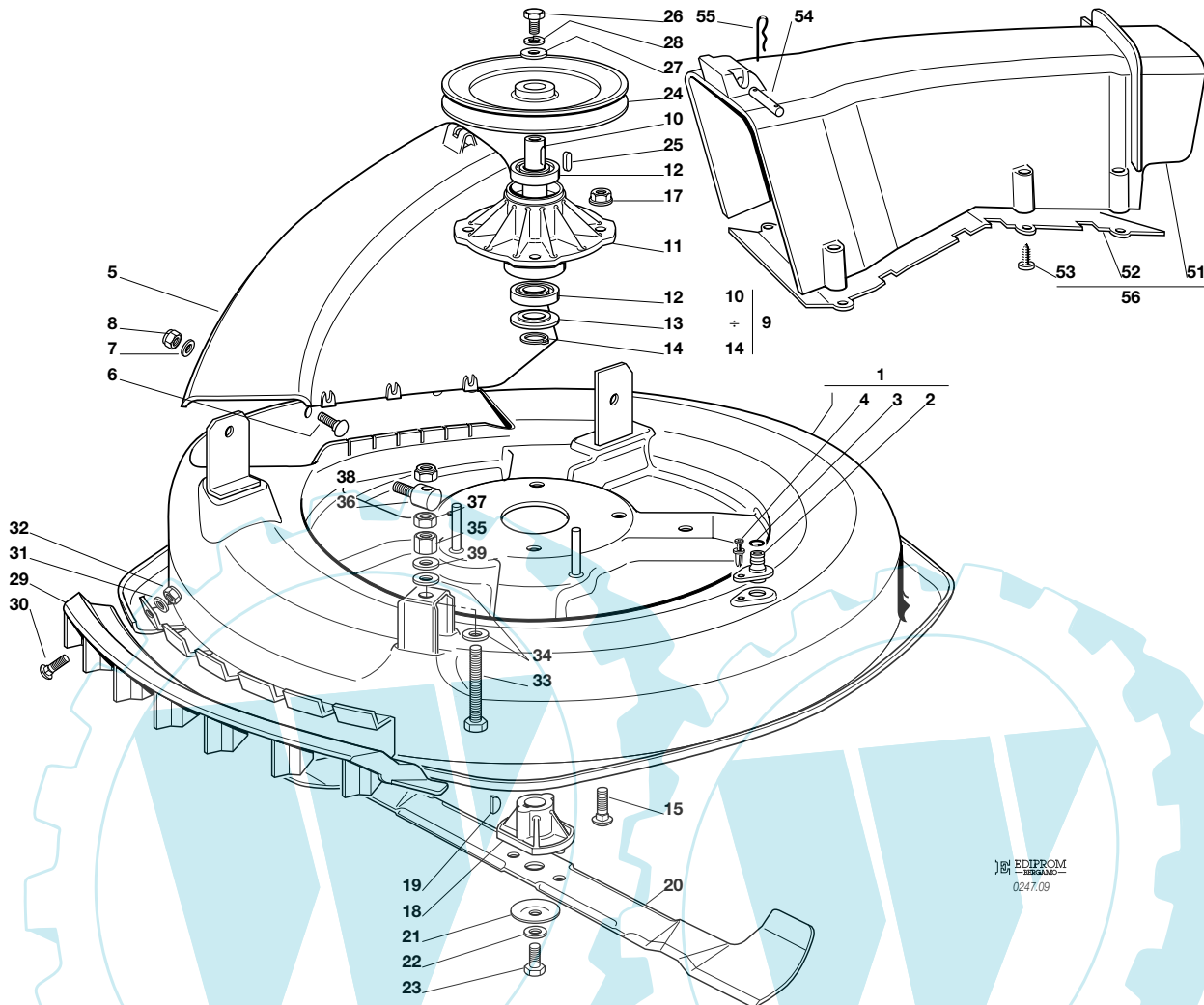

N.	CODE	Q.TY	DESCRIZIONE	DESCRIPTION	DESCRIPTION	BESCHREIBUNG
1	84564097/0	1	PIATTO	PLATE	PLATEAU	SCHNEID
2	25033060/0	1	ATTACCO	WATER HOSE CONNECTION	RACCORD TUYAU D'EAU	WASSERANSCHLUSS
3	19035000/0	1	ANELLO OR	O RING	O RING	O RING
4	12500030/0	1	RIVETTO	RIVET	RIVET	NIET
5	27045000/0	1	BOCCA CONVOGLIATORE	CONVEYOR INLET	BOUCHE CONVOYEUR	BLECHSATZEINGANG
6	12815210/0	6	VITE	SCREW	VIS	SCHRAUBE
7	12523040/0	6	ROSETTA	WASHER	RONDELLE	SCHEIBE
8	12154510/0	6	DADO	NUT	ECROU	MUTTER
9	84207250/0	1	ASS. FLANGIA (10÷14)	FLANGE ASS.Y (10÷14)	ENS. BRIDE (10÷14)	NABE, KOMPLETT (10÷14)
10	27023000/0	1	ALBERO	SHAFT	ARBRE	WELLE
11	27208402/0	1	FLANGIA	FLANGE	BRIDE	FLANSCH
12	19216032/0	2	CUSCINETTO	BEARING	ROULEMENT	KUEGELLAGER
13	25160501/0	1	DISCO PARAPOLVERE	DUST COVER	PROTEGE-POUSSIÈRE	STAUBSCHUTTSCHIEBE
14	12609260/0	1	SEEGER	SEEGER	SEEGER	SEEGER
15	12818700/0	4	VITE	SCREW	VIS	SCHRAUBE
17	12154210/0	4	DADO	NUT	ECROU	MUTTER
18	25463200/0	1	MOZZO COLTELLO	BLADE HUB	MOYEU LAME	MESSERHALTER
19	12139100/0	1	LINGUETTA	KEY	CLAVETTE	KEIL
20	84109503/0	1	COLTELLO	BLADE	LAME	MESSER
21	22160400/0	1	DISCO ELASTICO	ELASTIC WASHER	RONDELLE ELASTIQUE	FEDERSCHIEBE
22	12523080/0	1	RONDELLA	WASHER	RONDELLE	SCHEIBE
23	12735694/0	1	VITE	SCREW	VIS	SCHRAUBE
24	27604009/0	1	PULEGGIA	PULLEY	POULIE	RIEMENSCHIEBE
25	12139480/0	1	CHIAVETTA	KEY	CLAVETTE	KEIL
26	12793102/0	1	VITE	SCREW	VIS	SCHRAUBE
27	25670007/0	1	RONDELLA	WASHER	RONDELLE	SCHEIBE
28	12583500/0	1	GROWER	GROWER	GROWER	GROWER
29	27488000/0	1	GRIGLIA ASPIRAZIONE	AIR INTAKE GRILL	GRILLE D'ASPIRATION	ANSAUGGITTER
30	12815200/0	4	VITE	SCREW	VIS	SCHRAUBE
31	12521340/0	4	ROSETTA	WASHER	RONDELLE	SCHEIBE



 **F72 • F72 hydro**

2003

009.0

2 / 2

N.	CODE	Q.TY	DESCRIZIONE	DESCRIPTION	DESCRIPTION	BESCHREIBUNG
32	12154510/0	4	DADO	NUT	ECROU	MUTTER
33	12794970/0	1	VITE	SCREW	VIS	SCHRAUBE
34	12523080/0	2	ROSETTA	WASHER	RONDELLE	SCHEIBE
35	12154250/0	1	DADO	NUT	ECROU	MUTTER
36	25510007/1	1	PERNO	PIN	PIVOT	BOLZEN
37	12295200/0	1	DADO	NUT	ECROU	MUTTER
38	12156602/0	1	DADO	NUT	ECROU	MUTTER
39	12585100/0	1	RONDELLA	WASHER	RONDELLE	SCHEIBE
—	84564099/0		PIATTO DI TAGLIO ASSEMBLATO (008, 31÷72 + 009, 1÷39)	CUTTING PLATE, ASSEMBLED (008, 31÷72 + 009, 1÷39)	PLATEAU DE COUPE,S COMPLETE (008, 31÷72 + 009, 1÷39)	CHNEIDWERKZEUG, KOMPLETT (008, 31÷72 + 009, 1÷39)
51	27107501/0	1	CONVOGLIATORE	CONVEYOR	CONVOYEUR	BLECHSATZ
52	27140051/1	1	DEFLETTORE	DEFLECTOR	DEFLECTEUR	ABWEISER
53	12735402/0	8	VITE	SCREW	VIS	SCHRAUBE
54	27510097/1	1	PERNO	PIN	PIVOT	BOLZEN
55	24487997/0	2	COPPIGLIA	COTTER PIN	GOUPILLE	SPLIT
56	84108051/0	1	ASS. CONVOGLIATORE (51, 52, 53)	CONVEYOR ASS.Y (51, 52, 53)	ENS. CONVOYEUR (51, 52, 53)	BLECHSATZ, KOMPLETT (51, 52, 53)

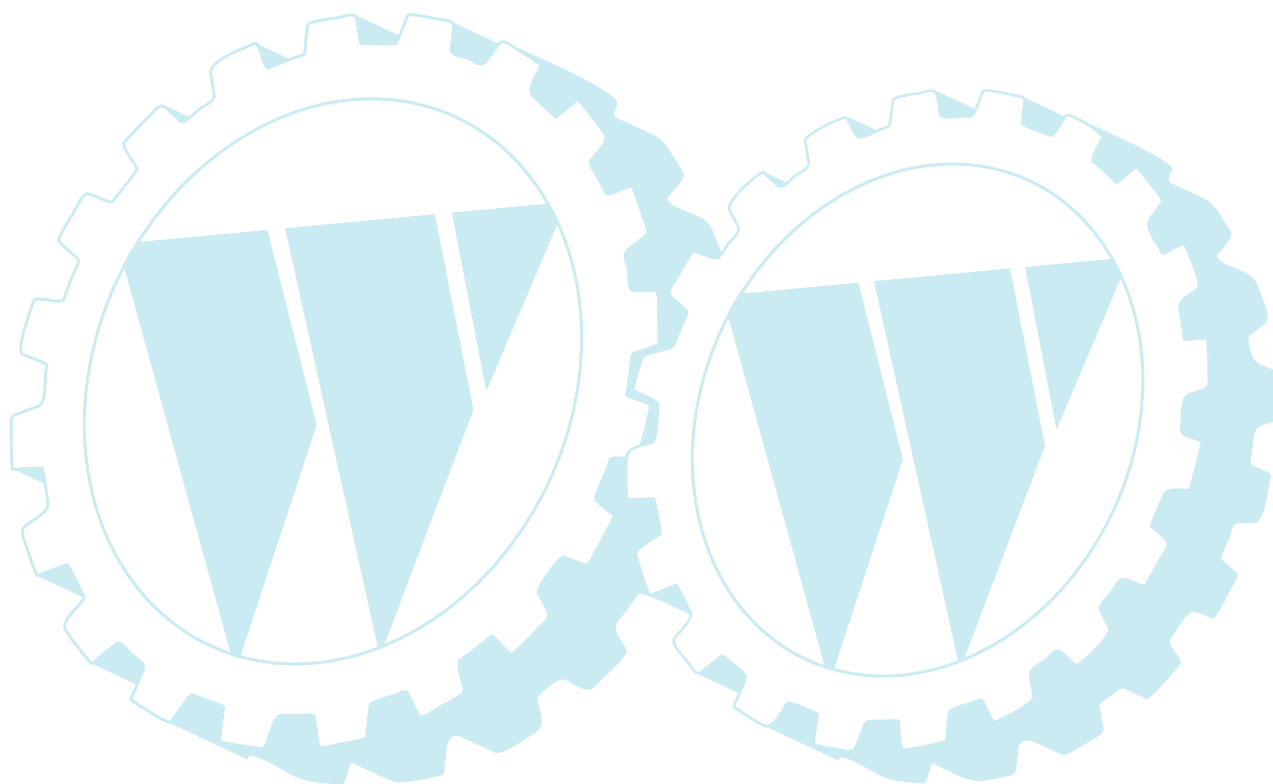

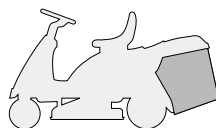
F72**F72 hydro**
**SACCO
GRASSCATCHER
BAC
AUFFANGSACK**

2003

010.0

1 / 1

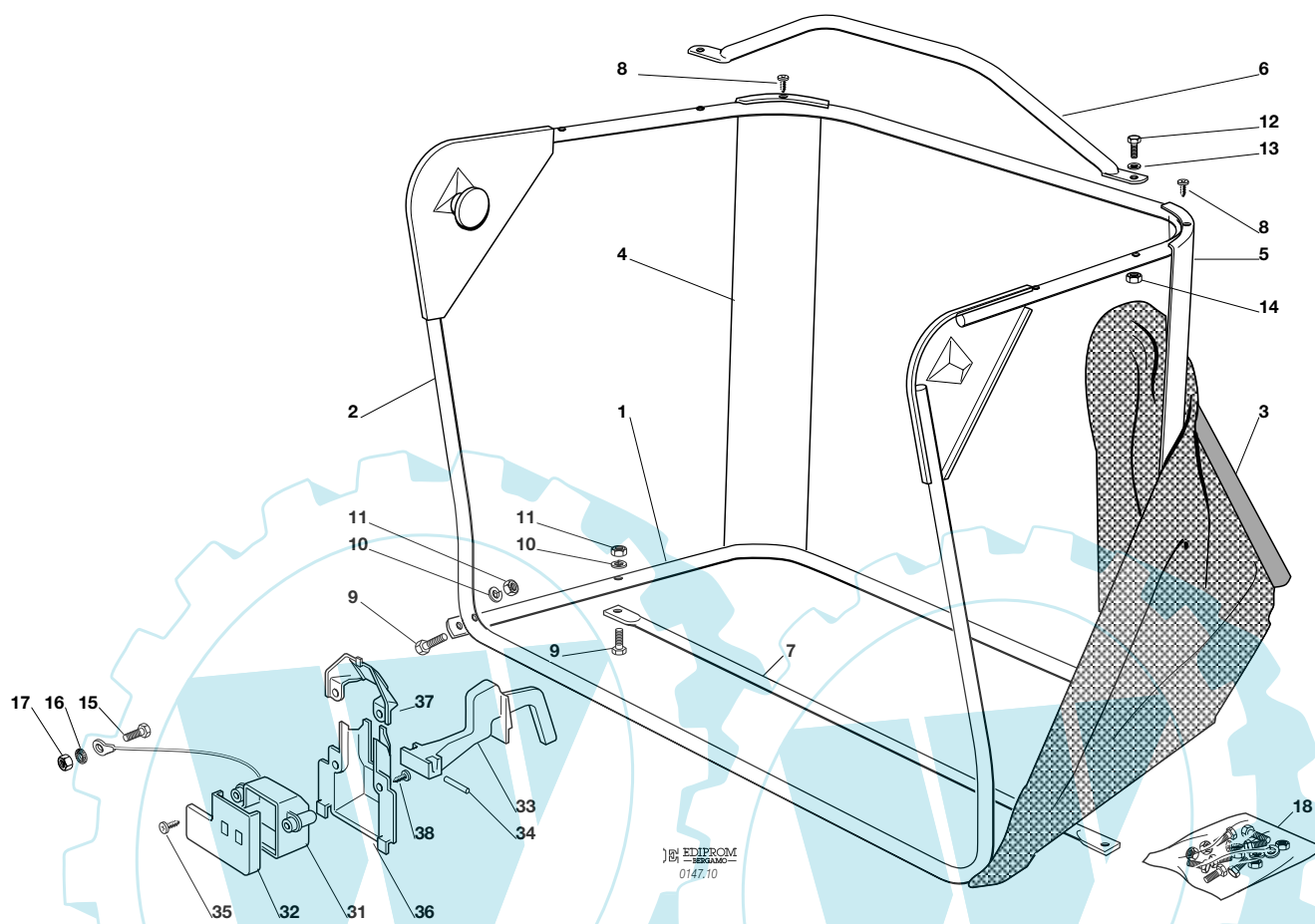

N.	CODE	Q.TY	DESCRIZIONE	DESCRIPTION	DESCRIPTION	BESCHREIBUNG
1	84801103/0	1	TELAIO INFERIORE	LOWER FRAME	CHASSIS INFÉRIEUR	UNTERERRAHMEN
2	84801105/0	1	TELAIO SUPERIORE	UPPER FRAME	CHASSIS SUPÉRIEUR	OBERERRAHMEN
3	84106050/0	1	CONFEZIONE SACCO	GRASSCATCHER	BAC	SACK
4	27010205/0	1	ANGOLARE DESTRO	RIGHT ANGULAR SUPPORT	SUPPORT ANGULAIRE DROITE	RECHTER HALTER
5	27010207/0	1	ANGOLARE SINISTRO	LEFT ANGULAR SUPPORT	SUPPORT ANGULAIRE GAUCHE	LINKER HALTER
6	84869051/0	1	TUBO	ROD	TIGE	STANGE
7	84650100/0	1	RINFORZO	STIFFENING	RENFORCEMENT	VERSTAERKUNG
8	12729601/0	4	VITE	SCREW	VIS	SCHRAUBE
9	12792099/0	2	VITE	SCREW	VIS	SCHRAUBE
10	12582101/0	4	GROWER	GROWER	GROWER	GROWER
11	12292100/0	4	DADO	NUT	ECROU	MUTTER
12	12674701/0	2	VITE	SCREW	VIS	SCHRAUBE
13	12521331/0	2	RONDELLA	WASHER	RONDELLE	SCHEIBE
14	12154510/0	2	DADO	NUT	ECROU	MUTTER
15	12790780/0	1	VITE	SCREW	VIS	SCHRAUBE
16	12540040/0	1	RONDELLA	WASHER	RONDELLE	SCHEIBE
17	12292102/0	1	DADO	NUT	ECROU	MUTTER
18	84180180/0	1	DOTAZIONE VITERIA (8÷17)	SCREWS OUTFIT (8÷17)	ENSEMBLE DES VIS (8÷17)	SCHRAUBENAUSRÜSTUNG (8÷17)
31	25600041/0	1	PROTEZIONE MICRO	MICRO PROTECTION	PROTECTION MICRO	SCHUTZ
32	25600042/0	1	COPERCHIO PROTEZIONE	PROTECTION COVER	COUVERCLE PROTECTION	SCHUTZDEKEL
33	25318124/0	1	LEVA	LEVER	LEVIER	HEBEL
34	12400030/0	1	PERNO	PIN	PIVOT	BOLZEN
35	12728510/0	3	VITE	SCREW	VIS	SCHRAUBE
36	25600047/0	1	DEFLETTORE	DEFLECTOR	DEFLECTEUR	ABWEISER
37	25600048/0	1	CHIUSURA DEFLETTORE	DEFLECTOR COVER	COUVERCLE DEFLECTEUR	ABWEISERDEKEL
38	12728510/0	4	VITE	SCREW	VIS	SCHRAUBE

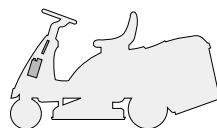
F72**F72 hydro**

PARTI ELETTRICHE
ELECTRICAL PARTS
PARTIES ELECTRIQUES
ELETRISCHE TEILE

2003

011.0

1 / 1

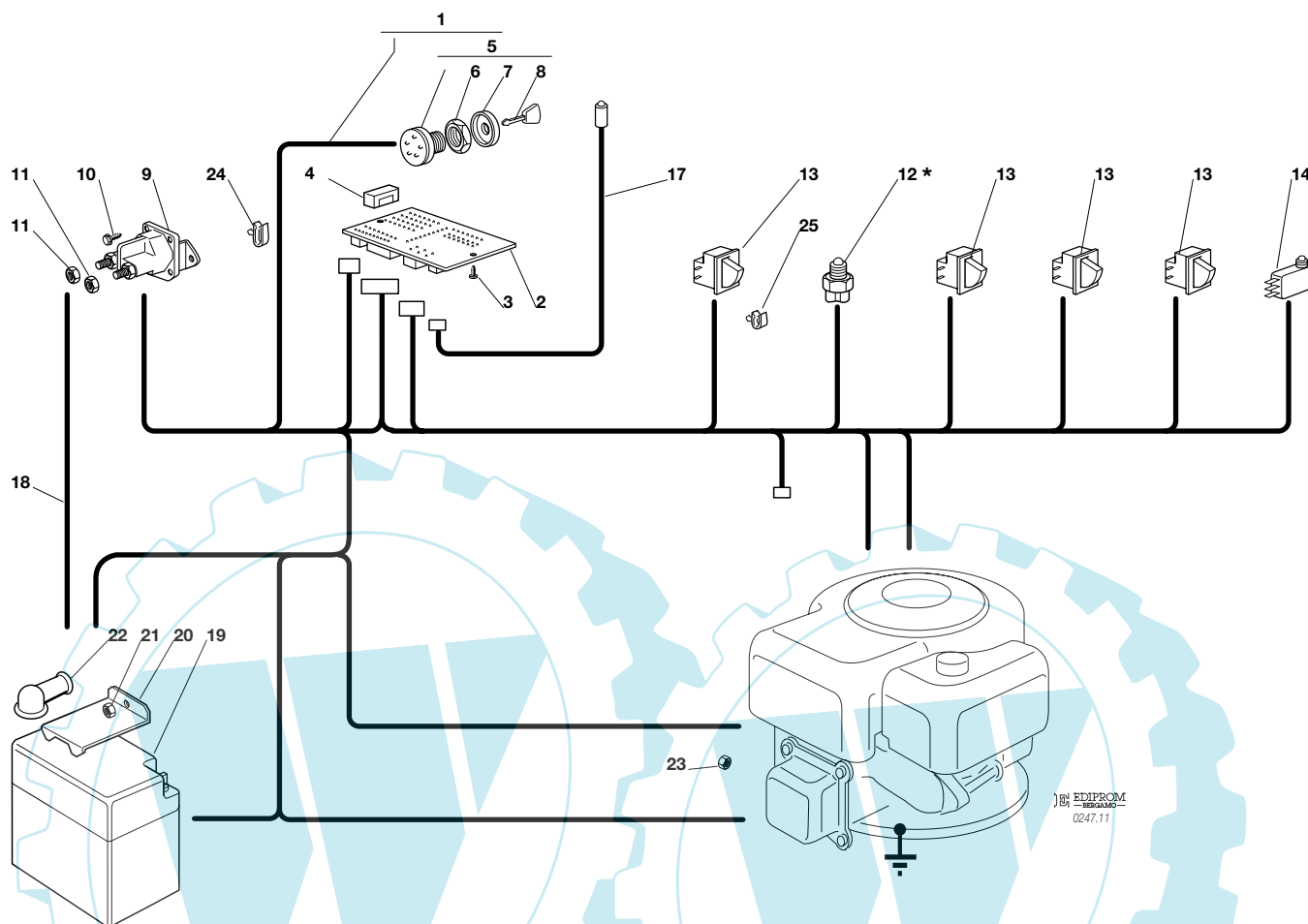

N.	CODE	Q.TY	DESCRIZIONE	DESCRIPTION	DESCRIPTION	BESCHREIBUNG
1	84040117/0	1	CABLAGGIO	CABLES	CABLAGES	KABELSATZ
2	25722415/0	1	SCHEDA ELETTRONICA	ELECTRONIC CARD	CARTE ELECTRONIQUE	ELEKTRONISCHE KARTE
3	12727810/0	2	VITE	SCREW	VIS	SCHRAUBE
4	33340033/0	1	FUSIBILE	FUSE	FUSIBLE	SICHERUNG
5	18450065/1	1	INTERRUTTORE AVVIAMENTO	STARTING SWITCH	INTERRUPTEUR DEMARRAGE	SCHALTER
6	18400861/0	1	GHIERA	SCREWED RING	EMBOUT	NUTMUTTER
7	18565351/0	1	PROTEZIONE GHIERA	SCREWED RING PROTECTION	PROTECTION EMBOUT	NUTMUTTER SCHUTZ
8	18210016/0	1	CHIAVE AVVIAMENTO	STARTING KEY	CLEF A DEMARRAGE	SCHLÜSSEL FÜR START
9	18736110/0	1	RELÉ AVVIAMENTO	STARTER RELAY	RELAIS D'ALLUMAGE	ANLASSRELAIS
10	12735110/0	2	VITE	SCREW	VIS	SCHRAUBE
11	12360352/0	2	DADO	NUT	ECROU	MUTTER
12*	-	1	INTERRUTTORE CAMBIO	GEARBOX SWITCH	INT. BOÎTE DE VITESSE	ANTRIEB SCHALTER
13	19410606/0	4	MICRO INTERRUTTORE	MICROSWITCH	MICROINTERRUPTEUR	MIKROSCHALTER
14	19410605/1	1	MICRO SACCO PIENO	FULL GRASSCATC. MICRO	MICRO BAC PLEIN	VOLLKORB VORRICHTUNG
17	25065014/1	1	CAVO LED SEGNALE	CABLE	CABLES	KABEL
18	27065050/0	1	CAVO BATTERIA SOLENOIDE	CABLE	CABLES	KABEL
19	18120002/1	1	BATTERIA	BATTERY	BATTERIE	BATTERIE
20	27772099/0	1	STAFFA	CLAMP	ETRIER	BRIDE
21	12155000/0	1	DADO	NUT	ECROU	MUTTER
22	18564861/1	1	CAPPUCCIO	PROTECTION	CAPUCHON	STECKER
23	12361005/0	1	DADO	NUT	ECROU	MUTTER
24	33320506/0	3	FERMACAVO	FAIRLEAD	FIXATION CABLE	KABELBEFESTIGUNG
25	33320504/0	1	FERMACAVO	FAIRLEAD	FIXATION CABLE	KABELBEFESTIGUNG

PER LA SOSTITUZIONE DELLE PARTI CONTRASSEGNALE CON «*» RIVOLGERSI AL SERVIZIO ASSISTENZA DEL COSTRUTTORE DELLA TRASMISSIONE.

TO REPLACE THE PARTS MARKED «*» SEEK ASSISTANCE FROM THE TRANSMISSION MANUFACTURER'S AFTER SALES SERVICE.

POUR LE REMPLACEMENT DES PIÈCES MARQUÉES AVEC «*» S'ADRESSER AU SERVICE APRÈS VENTES DU CONSTRUCTEUR DE LA TRANSMISSION.

ZUM AUSTAUSCH DER MIT «*» GEKENNZEICHNETEN TEILE, WENDEN SIE SICH AN DEN KUNDENDIENST DES HERSTELLERS DES ANTRIEBS.

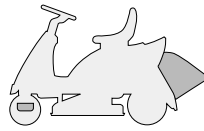
F72**F72 hydro**

ACCESSORI A RICHIESTA
OPTIONALS ON REQUEST
ACCESSOIRES SUR DEMANDE
ZUBEHOERE NACH ANFRAGE

2003

012.0

1 / 2

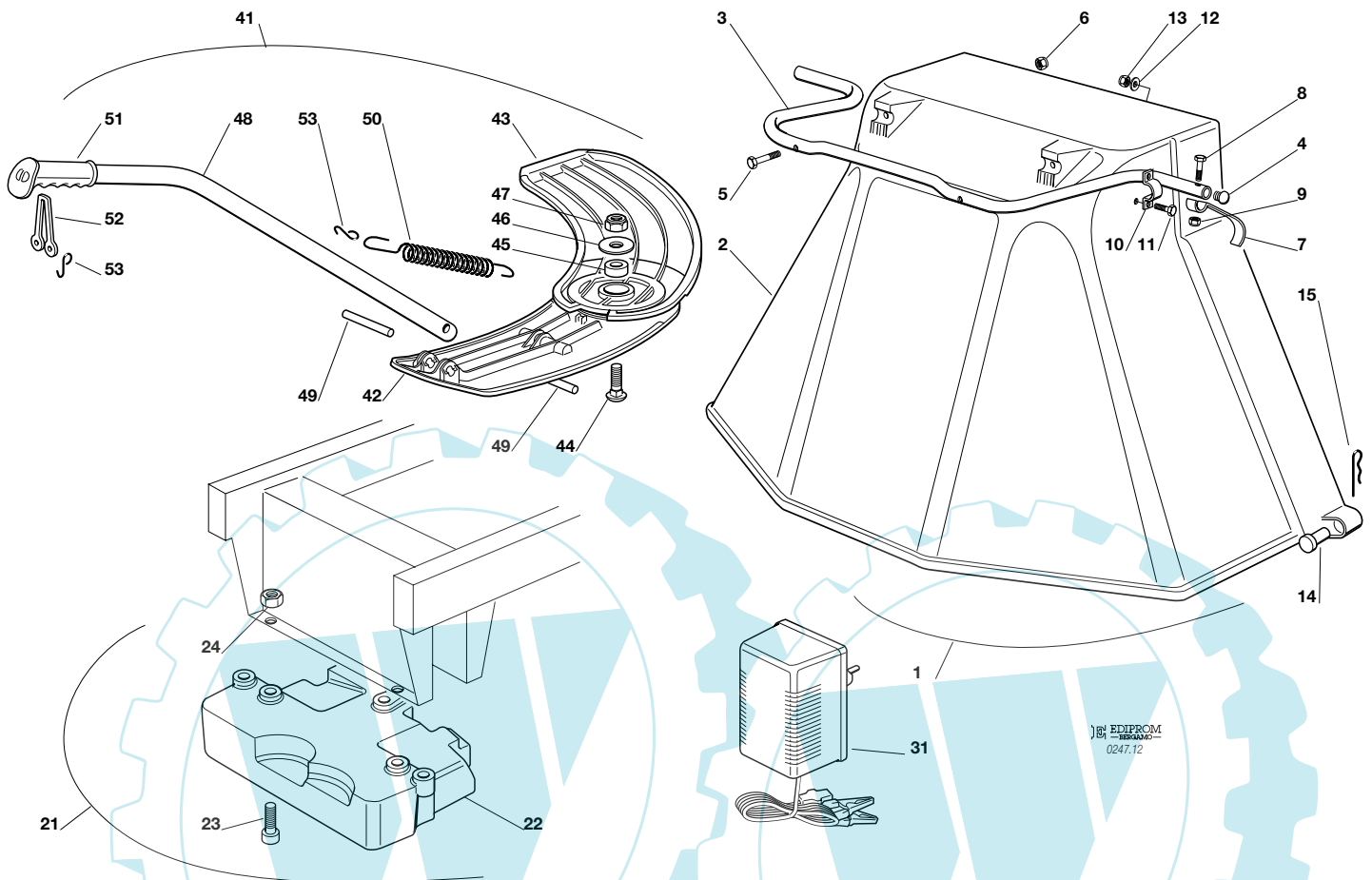

N.	CODE	Q.TY	DESCRIZIONE	DESCRIPTION	DESCRIPTION	BESCHREIBUNG
1	99900090/0	1	ASS. KIT PROTEZIONE USCITA	EJECTION-GUARD ASS.Y	KIT PROTECTION SORTIE	VORRICHTUNG FÜR AUSWURESCHUTZ
2	84598062/0	1	PROTEZIONE USCITA	EJECTION GUARD	PROTECTION SORTIE	AUSWURFSCHUTZ
3	27869053/0	1	TUBO DI AGGANCIO	SUPPORT	SOPPORT	HALTER
4	18566113/0	2	PUNTALE	CAP	BOUCHON	PFROPFEN
5	12674701/0	2	VITE	SCREW	VIS	SCHRAUBE
6	12154510/0	2	DADO	NUT	ECROU	MUTTER
7	25547053/0	1	PIASTRINA	PLATE	PLAQUETTE	PLÄTTCHEN
8	12791500/0	1	VITE	SCREW	VIS	SCHRAUBE
9	12154510/0	1	DADO	NUT	ECROU	MUTTER
10	25547049/0	2	PIASTRINA	PLATE	PLAQUETTE	PLÄTTCHEN
11	12788910/0	4	VITE	SCREW	VIS	SCHRAUBE
12	12523020/0	4	ROSETTA	WASHER	RONDELLE	SCHEIBE
13	12154320/0	4	DADO	NUT	ECROU	MUTTER
14	25510022/0	2	PERNO	PIN	PIVOT	BOLZEN
15	24487998/0	2	COPPIGLIA	COTTER PIN	GOUPILLE	SPLIT
21	99900030/6	1	ASS. KIT PESO ANT.	FRONT WEIGHT KIT	KIT POIDS ANTERIEUR	VORDERGEWICHT VORRICHTUNG
22	25519997/1	1	PESO	WEIGHT	POIDS	GEWICHT
23	12760520/0	3	VITE	SCREW	VIS	SCHRAUBE
24	12155000/0	3	DADO	NUT	ECROU	MUTTER
31	82180050/0	1	CARICA BATTERIE	BATTERY CHARGER	CHARGEUR DE BATTERIES	BATTERIELADEGERÄT
41	99900036/0	1	KIT MULCHING	MULCHING KIT	KIT MULCHING	MULCHINGVORRICHTUNG
42	27140055/0	1	DEFLETTORE POST.	DEFLECTOR, REAR	DEFLECTEUR, ARRIERE	ABWEISER, HINTER
43	27140054/0	1	DEFLETTORE ANTER.	DEFLECTOR, FRONT	DEFLECTEUR, AVANT	ABWEISER, VORDER



 **F72 • F72 hydro**

2003

012.0

2 / 2

N.	CODE	Q.TY	DESCRIZIONE	DESCRIPTION	DESCRIPTION	BESCHREIBUNG
44	12818700/0	1	VITE	SCREW	VIS	SCHRAUBE
45	27047013/0	1	BUSSOLA	BUSHING	DOUILLE	LAGER
46	22672152/0	1	RONDELLA	WASHER	RONDELLE	SCHEIBE
47	12155000/0	1	DADO	NUT	ECROU	MUTTER
48	27394003/1	1	MANICO	HANDLE	GUIDON	STIEL
49	27510116/0	2	PERNO	PIN	PIVOT	BOLZEN
50	25430229/1	1	MOLLA	SPRING	RESSORT	FEDER
51	25280000/1	1	IMPUGNATURA	HANDGRIP	BRANCHE	GRIFF
52	25840011/0	1	TIRANTE IN GOMMA	ELASTIC TIE-ROD	TIRANT ELASTIQUE	ELASTISCHE ZUGSTÄBE
53	25253004/0	3	GANCIO	HOOK	CROCHET	HAKEN

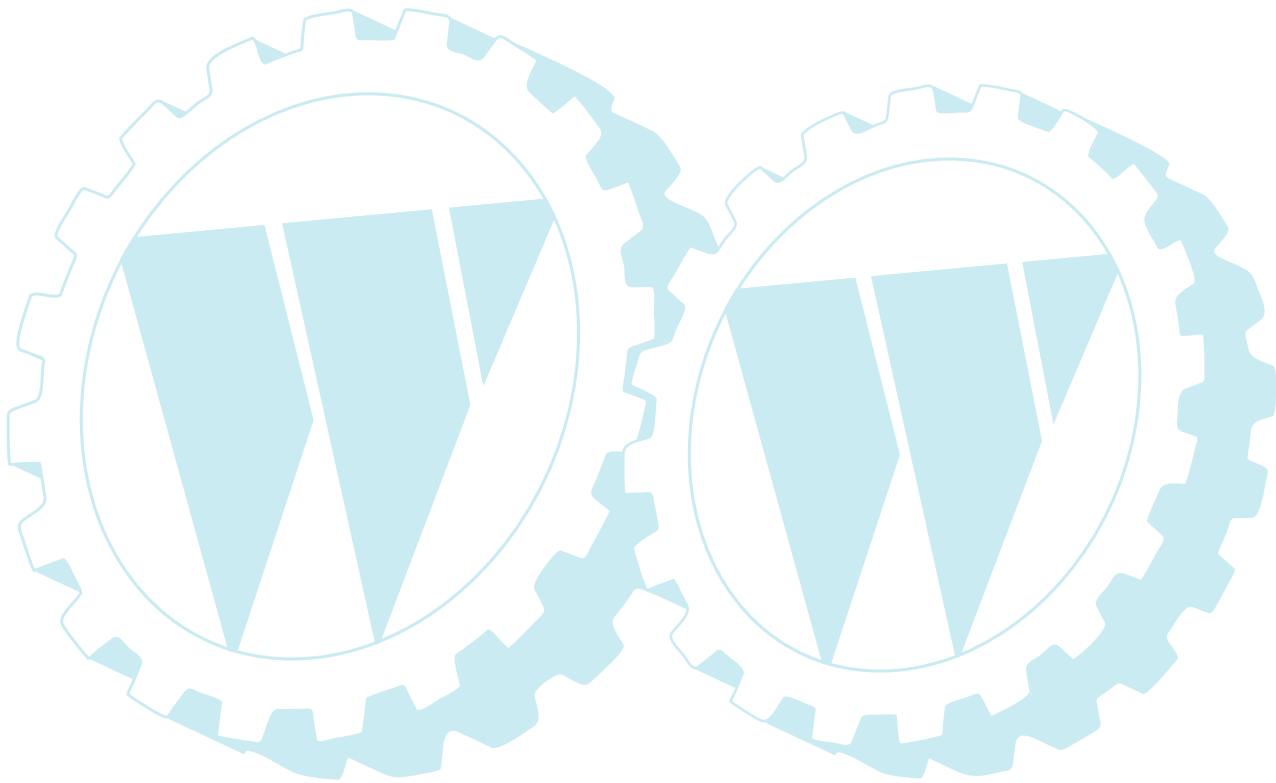

F72

F72 hydro

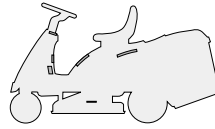

**ETICHETTE
LABELS
ETIQUETTES
KLEBZETTEL**

2003

013.0

1 / 1

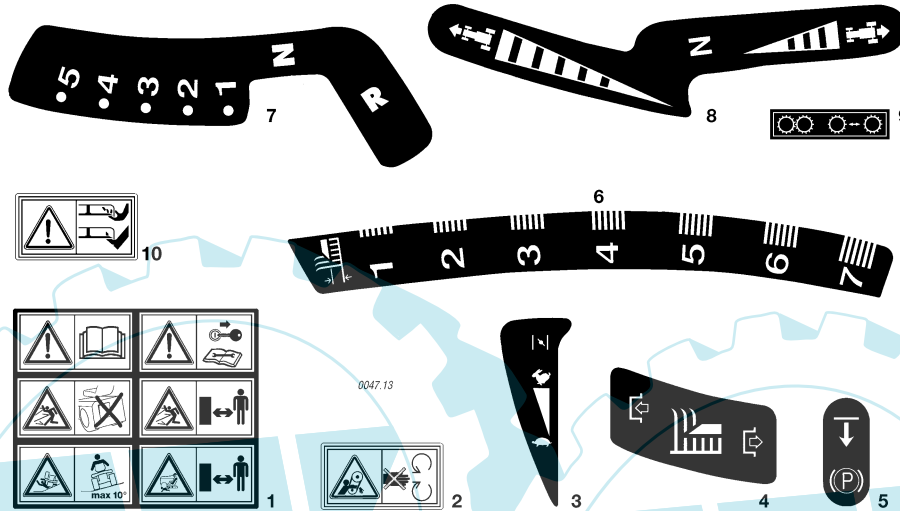

N.	CODE	Q.TY	DESCRIZIONE	DESCRIPTION	DESCRIPTION	BESCHREIBUNG
1	14357428/0	1	ETICHETTA	LABEL	ETIQUETTE	KLEBZETTEL
2	14357519/1	1	ETICHETTA	LABEL	ETIQUETTE	KLEBZETTEL
3	14357425/0	1	ETICHETTA	LABEL	ETIQUETTE	KLEBZETTEL
4	14357431/0	1	ETICHETTA	LABEL	ETIQUETTE	KLEBZETTEL
5	14357526/0	1	ETICHETTA	LABEL	ETIQUETTE	KLEBZETTEL
6	14357427/0	1	ETICHETTA	LABEL	ETIQUETTE	KLEBZETTEL
7	14357426/0	1	ETICHETTA (mecc.)	LABEL (mech.)	ETIQUETTE (mec.)	KLEBZETTEL (mech.)
8	14357702/0	1	ETICHETTA (hydro)	LABEL (hydro)	ETIQUETTE (hydro)	KLEBZETTEL (hydro)
9	14357423/1	1	ETICHETTA (hydro)	LABEL (hydro)	ETIQUETTE (hydro)	KLEBZETTEL (hydro)
10	14356699/0	2	ETICHETTA	LABEL	ETIQUETTE	KLEBZETTEL